

- Timber
- Aluminium
- Concrete

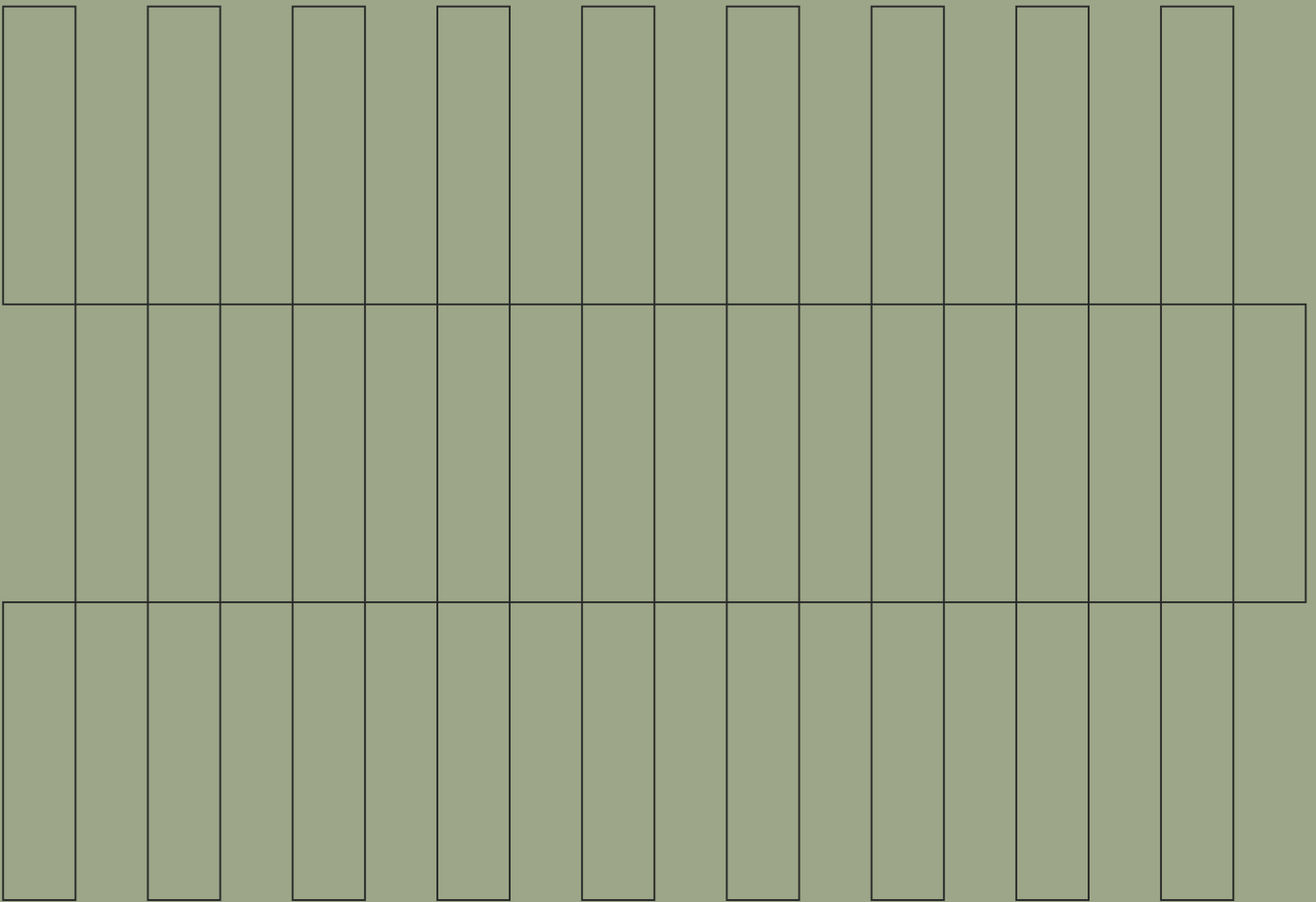

Thermally Modified Hemlock

Installation Guide

Technical Data

Wood Species

Images



Quality

Select Grade/face and edges virtually free of any defects (one edge knot and one small face defect allowed per piece in 20% of boards only), back face allows some isolated defects. Vertical Grain orientation on all boards.

Moisture Content

Kiln Dried, 8.6% MC (+/-%)

Sizes

Thickness (x width mm)

- 120 x 18 mm (120mm cover)
- 125 x 20 mm (125mm cover)
- 135 x 16.5 mm (110mm effective cover)
- 180 x 16.5 mm (155mm effective cover)

Length (cm)

3600, 3900, 4200, 4500, 4800 mm - Set Length Packets (Length Subject to Availability)

Profile



PR-CLS5E-TMH-120X18



PR-VHC-TMH-125X20



TMH SHIPLAP PROFILE 135 X18.5MM (110MM COVER)



TMH SHIPLAP PROFILE 180 X18.5MM (115MM COVER)

Colours/Species



Raw



Patina Oiled



Walnut Oiled

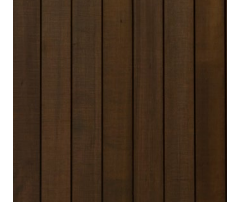

Ebony Oiled



Graphite Oiled



Thermally Modified Hemlock vertical fix



Thermally Modified Hemlock horizontal fix

Product Specifications

Treatment

Thermally modified to TM2200 schedule. H3 Treated with Protim preservation system. Durability class H3 (AS1604)

Density

560.8kg/m³

Weight

light weight cladding
13kg/m² (110mm cover)
17kg/m² (155mm cover)

Hardness

Medium-Low

Wind Zone

Acceptable for wind zones up to and including N4 (non-cyclonic areas) and C2 (cyclonic areas). Alternative fixing details from a registered engineer may be required for cyclonic areas with C3 wind classification.

Intended Use

Intended use in residential and light commercial buildings.

Finishing

Fine bandsawn face.

Coating

Supplied with 1 coat of factory-applied Resene Paints penetrating Water Borne Oil, or other proprietary wood stain coated all sides.

Expected Dimensional Change in Service

Width expansion approx 2% length expansion approx 0.5% thickness expansion approx 3% (variation may occur between boards).

Expected Service Life

Minimum 30 years or more when properly maintained.

Warranty

25 years against rot, fungal decay and insect attacks (subject to terms and conditions).

Forestry Certification

PEFCTM - Chain of custody of forest based products

Handling

- Weatherboards and accessories must be kept clean dry, under cover and out of the weather prior to Installation.
- Timber must be stored horizontally on bearers at least 100mm off the ground.
- Extra care must be taken during Installation so as not to damage the factory finish of the boards.
- Wear dust mask, eye protection when cutting timber.
- Do not burn treated timber. Dispose of off-cuts in lined land fill or an approved furnace.

Installation Instructions

Horizontal Installation Instructions:

1. Pre coat the cladding boards all round prior to installation and group similar lengths together for efficient optimization. Take advantage of our pre-oiling service, to save time, labour and space on site, providing an even coating on all 4 sides of the boards.

Pre Oiling System

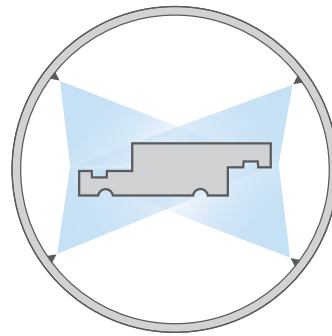

Eliminates process of manually oiling each board all-round prior to installation

Gives the penetrating oil a change to soak in prior to handling the timber

The deeply penetrating oil, working from front & back of the board, improves dimensional stability.

Requires a topcoat after installation

2. Install impermeable sarking over the stud frame keeping all overlaps pointing downwards and tape all joints.
3. Check stud work for straightness and plumb. Ensure correct provision had been made for external corner stop fixing. Studs to be max. 450 mm centres.
4. Install all corner stops and end stops (or aluminium trims).

Face fixing showing fixing position

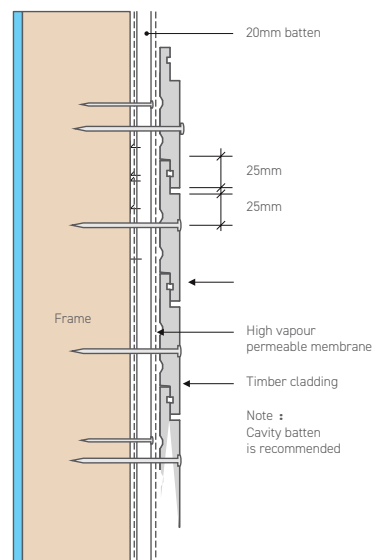

Face fixing showing fixing position

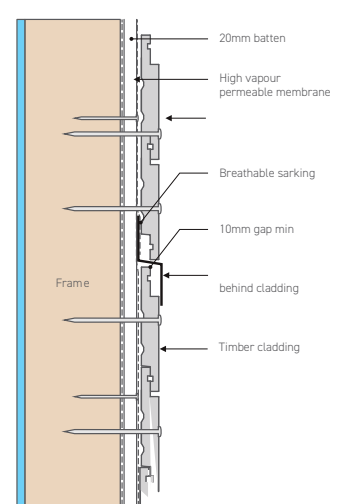

Horizontal installation – external

5. Install starter board checking for level at all points.
6. Using a gauging stick, mark the cover increments of each row up the studs off the top of the starter board to keep everything straight and parallel. This is particularly important around windows and doors. Alternatively use a spacer block in the shadow line to assist even spacing.
7. Install the cladding boards, following the increments marked on the studs. In some tropical climates the 2mm expansion allowance may need to be increased due to high moisture conditions. It may be necessary to lubricate the gaskets in the end stops with dishwashing liquid to help slip the boards in easily. Pre-drill a countersunk and clearance hole prior to drilling in the screws. If nailing, ensure nails are installed with the head flush to the surface of the timber. Do not drive in deeper as this may cause the timber to crack, losing the holding power of the nail.
8. Butt joints should be joined on the studs. All butt joints should be sealed with 'sikaflex' or similar joint sealant. The easiest way to apply the joint sealant is to apply it to the end of one board and allow it to squeeze out as the two boards are pushed together. The excess sealant will mushroom off the two edges. Let it dry fully, and then scrape it flush with a sharp chisel.
9. All end grain is to be sealed with multiple coats of the timber preservative to be used on the face.

Minimum clearance level of cladding above final ground levels and finishing below bottom plate

Minimum clearance of cladding above final ground

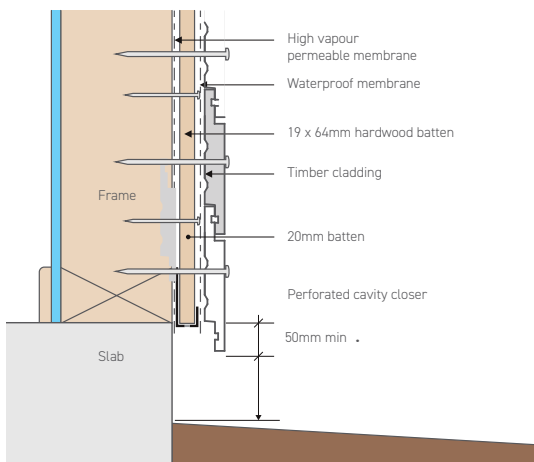

Vertical Installation Instructions:

1. Pre coat the cladding boards all round prior to installation and group similar lengths together for efficient optimisation. Take advantage of our pre-oiling service, to save time, labour and space on site, providing an even coating on all 4 sides of the boards.
2. Install impermeable sarking over the stud frame keeping all overlaps pointing downwards and tape all joints. Attach horizontal battens at 450 mm centres. These may be packed out to ensure straightness if necessary. Use 70x35 mm pine framing or similar material.
3. Install all external corner stops, Z flashings and bottom angles onto the horizontal battens.
4. Using a gauging stick, mark the cover increments of each row along the battens to keep everything straight and parallel. This is particularly important around openings. Alternatively use a spacer block in the shadow line to assist even spacing.
5. Install the cladding boards following the increments marked on the battens. In some tropical climates, the 2mm expansion allowance may need to be increased due to high moisture conditions.
6. Pre-drill a countersunk and clearance hole prior to drilling in the screws. If nailing, ensure nails are installed with the head flush to the surface of the timber. Do not drive in deeper as this may cause the timber to crack, losing the holding power of the nail.

Expansion Gap Detail A

Vertical installation

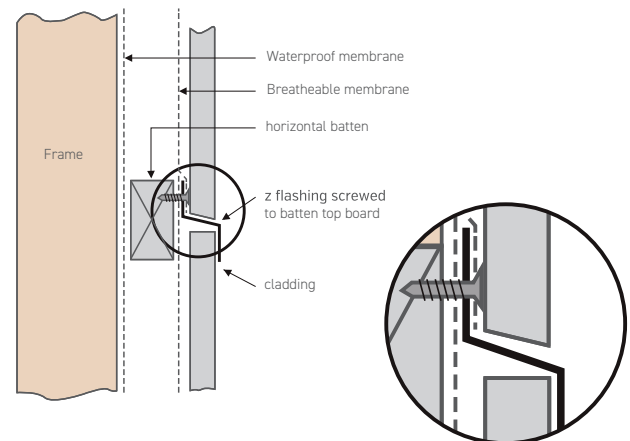

Stud Frame Detail Typical vertical installation

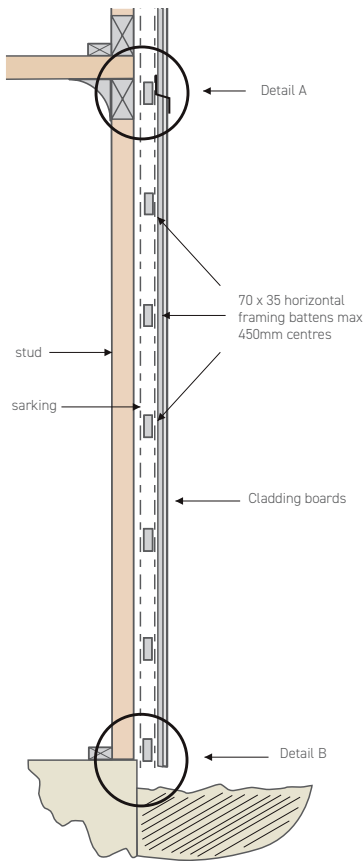

Bottom Edge - Detail B

Vertical installation

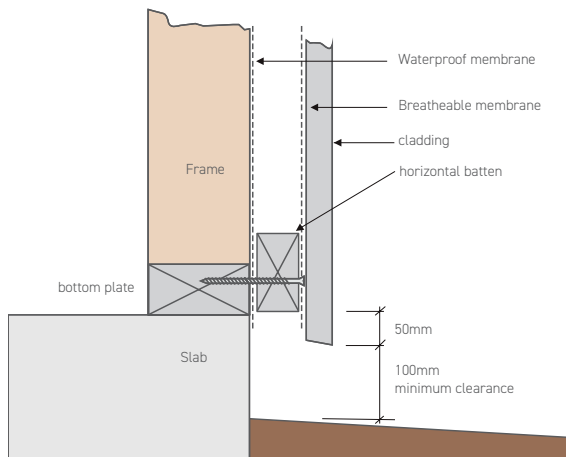

Section Details

Profile Accuracy

It is necessary to predict, as far as possible, the range of movement to be expected in a given application. This can then be allowed for by: leaving room for expansion between the boards, expansion joints if necessary, choosing suitable species or changing the width of a board. Install impermeable sarking over the stud frame keeping all overlaps pointing downwards and tape all joints. Attach horizontal battens at 450 mm centres. These may be packed out to ensure straightness if necessary. Use 70x35 mm pine framing or similar material.

On-Site Storage & Acclimatisation

- Tangential shrinkage rate of the species (rate of shrinkage across the width of a backsawn board).
- Annual cycle of weather
- Level of exposure to sun/weather i.e. Direction, overhanging eaves, shadows etc.
- Size of the area to be clad.
- Waterproofing and water runoff
- Weather protection in construction.

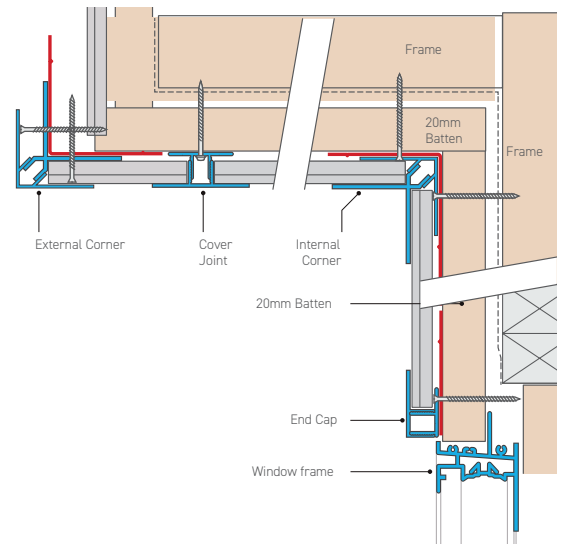

Internal / external stops (Aluminium)

Concealed Fixing Details for Internal Installations:

1. Check stud work for straightness and plumb. Ensure correct provision had been made for external corner stop fixing. Studs to be max. 450 mm centres.
2. Install all corner stops and end stops.
3. Install starter board checking for level at all points.
4. Using a gauging stick, mark the cover increments of each row up the studs off the top of the starter board to keep everything straight and parallel. This is particularly important around windows and doors. Alternatively use a spacer block in the shadow line to assist even spacing.
5. Install the cladding boards, following the increments marked on the studs. In some tropical climates the 2mm expansion allowance may need to be increased due to high moisture conditions. It may be necessary to lubricate the gaskets in the end stops with dishwashing liquid to help slip the boards in easily. Pre-drill a countersunk and clearance hole prior to drilling in the screws. If nailing, ensure nails are installed with the head flush to the surface of the timber. Do not drive in deeper as this may cause the timber to crack, losing the holding power of the nail.
6. Butt joints should be joined on the studs. All butt joints should be sealed with 'sikaflex' or similar joint sealant. The easiest way to apply the joint sealant is to apply it to the end of one board and allow it to squeeze out as the two boards are pushed together. The excess sealant will mushroom off the two edges. Let it dry fully, and then scrape it flush with a sharp chisel.
7. All end grain is to be sealed with multiple coats of the timber preservative to be used on the face.

The standard profile design allows 2 mm expansion and 7 mm contraction which is sufficient for normal conditions. The important thing is to identify the possibility of excessive conditions and make sure these are provided for. Modinex offer the service, on request, of calculating the maximum moisture content and hence the expansion and contraction in an area based on the information provided by the Bureau of Meteorology and the tangential shrinkage factor.

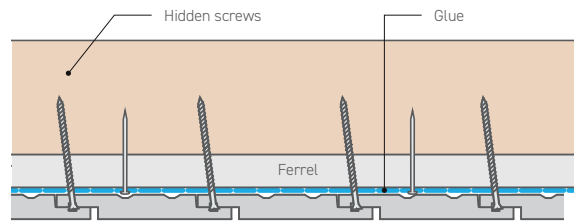

Horizontal installation – internal ceiling

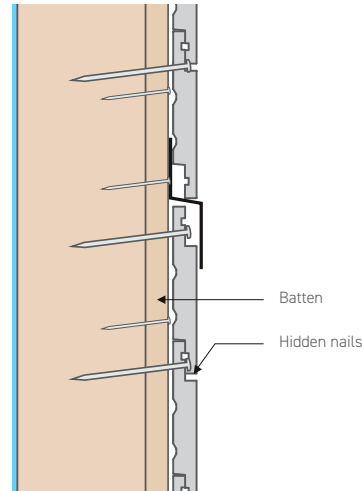

Horizontal installation – internal wall

Design Specification

To assist in achieving your desired result, the following information should be drafted into your project specifications to ensure that inferior products are not used on your project. All denoted façade areas to be Shiplap Cladding, supplied according to the following specification and installed in accordance with the Building Codes of Australia, and the manufacturer's installation guidelines.

Surface Finish

Furniture grade smoothness, ready for oiling – top surface only. Minimal chipping may occur with interlocking grain.

Moisture Content

Within a range of 8-9% M/C

Straightness

Max warp/bow – 2 mm per metre.

Grade

Natural Select (min 2/3 Select, max 1/3 Standard according to AS 2796.2) Minimal surface checking allowed. Graded top face only.

Length

All timber is supplied in random length, ranging from 0.9m to 6.0m, unless otherwise specified. Average length = +/-2.7m. Max of 15% under 1.8m.

Colour Selection

Colour selection is not part of the grading process except with extreme variations according to the discretion of Modinex. Colours can vary significantly from rich browns to greys. This is a natural characteristic of timber.

Specification Variance

Up to 5% of volume. Pre-Oiling with Cutek Wood Preservative Option. This option provides the application of 1 clear coat of Cutek Wood Preservative to all 4 sides of each board. Further applications are required after installation to maintain the appearance of the timber – refer to timber finishes section.

Profile Accuracy

Machining tolerance measured at time of manufacture is +/- 0.2 mm in dimension and profile. Due to variance in timber moisture and characteristics, boards may swell or contract individually when exposed to the elements.

On-site Storage & Acclimatisation

All timber should be stored undercover, on bearers at least 50 mm above ground and with plenty of airflow.

- Timber that is not neatly stacked is much more likely to twist or warp.
- At least two weeks acclimatisation period is necessary in areas of extreme weather conditions to avoid excessive expansion and contraction after installation.
- The cladding boards could be coated at this stage if the timber has not been supplied preoiled.
- External cladding is one of the harshest applications for timber surface finishes due to the destructive UV rays of the hot Australian Sun. As a result, ease of maintenance is a prime consideration. We recommend a good quality oil which is very easily applied using a lamb's wool applicator

Surface Finishes

Advantages of Oils

- Brings out the natural beauty and character of the timber.
- Penetrates and feeds the timber, providing dimensional stability
- Allows the timber to breathe.
- Tends to disappear and thin out when breaking down without blistering and peeling.
- Can be quickly reapplied by an unskilled person using a lamb's wool applicator.

We recommend and supply Resene Paints system. Ask for a brochure for further details. It is important to note that a clear coating on exterior wood surfaces will quickly lighten/silver in a few months of direct sun exposure. It gives a beautiful natural look associated with timber. If however you wish to delay the weathered look of the timber then apply a Colourtone to the Oil to provide some UV protection giving the cladding a freshly oiled timber aesthetic.

Maintenance

Natural timber needs maintenance. Maintenance is required regardless of whether you want the rich pristine 'coated' timber look or the natural greyed off affect. The timber cells need to be hydrated and fed, to avoid them separating and shrivelling up which results in cracking and twisting. The frequency of oil application required depends on the following factors:

- Level of exposure to the sun
- Level of local rainfall
- The level of UV block provided by the coating
- The extent of exposure to the western sun

Modinex recommends Resene Paints and the coating must be reapplied as frequently as necessary to retain the natural beauty and colour of the timber.

Face Fixing of Lining

Tables 1 and 2 provide further details on specific nail types and sizes for face fixing of lining for different underlying framing of 80 mm lining boards, respectively.

All nails are to be flat, D or bullet headed. The recommended nail diameter should not be exceeded otherwise splitting may occur.

Where lining is installed over a cavity the battens need to be fixed to studs as per minimum recommendations detailed under each lining installation method.

Table 1: Minimum hand driven nail sizes for face fixing of 80mm lining boards to timber framing or cavity battens

Timber framing/ batten type	Hardwood	Softwood
Nail size and type	50 x 2.0mm plain	60 x 2.8mm twisted or annular treaded
Minimum penetration	30mm	40mm

Table 2: Minimum hand driven nail sizes for face fixing of 130mm lining boards to timber framing or cavity battens

Timber framing/ batten type	Hardwood	Softwood
Nail size and type	50 x 2.0mm plain	60 x 2.8mm twisted or annular treaded
Minimum penetration	30mm	40mm

Nails should be placed at least 15 mm from the edge and end of lining board.

Where machine nails or screws are used they need to be equivalent in performance to nails defined in Table 1 and 2.

As machine nails and screws vary from manufacturer to manufacturer, the manufacturer should be consulted regarding the adequacy of the fixing.

T-nails should never be used.

Face fixing showing fixing position

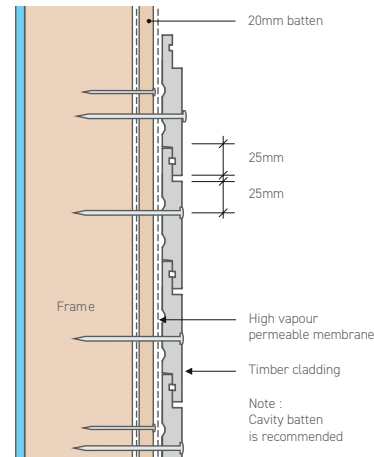

Secret Fixing of Lining

Lining profiles may be secret fixed using one fixing per intersection with batten, stud or bottom chord - driven into tongue at an angle. See Figure below from Internal Section of attached install Guide - page 6.

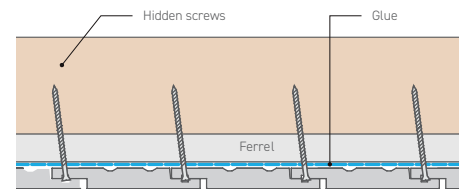

Horizontal installation - internal ceiling

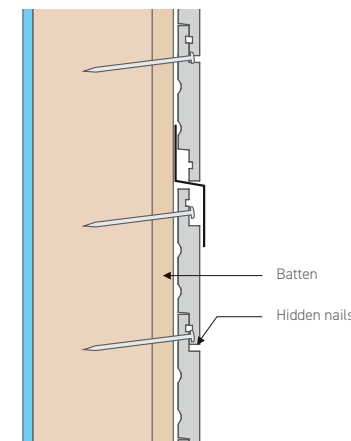

Horizontal installation - internal wall

Secret fixed boards also need to be glued to the batten. A continuous bead (6 mm to 10 mm approximately) of adhesive rated for exterior use is to be applied to the batten before fixing.

Tables 3 and 4 provide further details on specific nail types and sizes for secret fixing of lining for different underlying framing of 80 mm lining boards, respectively. All nails to be flat, D or bullet headed.

The recommended nail diameter should not be exceeded otherwise splitting may occur. Where lining is installed over a cavity the battens need to be fixed to studs as per minimum recommendations detailed under each lining installation method.

Table 3: Minimum hand driven nail sizes for secret fixing of 80mm lining boards to timber framing or cavity battens

Timber framing/ batten type	Hardwood	Softwood
Nail size and type	50 x 2.0mm plain	60 x 2.8mm twisted or annular treaded
Minimum penetration	30mm	40mm

Table 4: Minimum hand driven nail sizes for secret fixing of 130mm lining boards to timber framing or cavity battens

Timber framing/ batten type	Hardwood	Softwood
Nail size and type	50 x 2.0mm plain	60 x 3.75mm twisted or annular treaded
Minimum penetration	30mm	40mm

Soffits and Eaves

For design of soffits, external ceiling and eaves in terms of connections and sub structure please refer to cladding design and installation sections.

Suggested Adhesives

For design of soffits, external ceiling and eaves in terms of connections and sub structure please refer to cladding design and installation sections.

Disclaimer

Thermally Modified Hemlock is a new species

in AUS/NZ. The Modinex Group as custodians of compliant solutions to the building industry, have embarked on extensive testing to TMH so that

we can give the industry a definitive durability rating. This process however takes over 3 years to complete. We have thermally modified hemlock against wood decay fungi in a soil block bioassay in late 2019.

What we have discovered so far is very promising:

Thermally Modified Hemlock (TMH) is more durable than the class 4 timbers (hemlock

and radiata pine), and less durable than the class 1 timbers (blackbutt and spotted gum).

In comparison to the class 3 timbers, TMH was more durable than messmate, but less durable than brush box. Compared to class 2 timbers, TMH was more durable than WRC, but less durable than jarrah.

This bioassay suggests that the durability of TMH resides within the classes 2-3 range. An above ground field test against decay fungi and termites would be required to confirm durability.

Until this testing is complete, we recommend utilising Cutek Extreme in Humid and/or Termite designated areas and Reserve Paints penetrating Water Borne Oil, or other proprietary wood stain coated all sides in other areas.

