

- Timber
- Aluminium
- Concrete

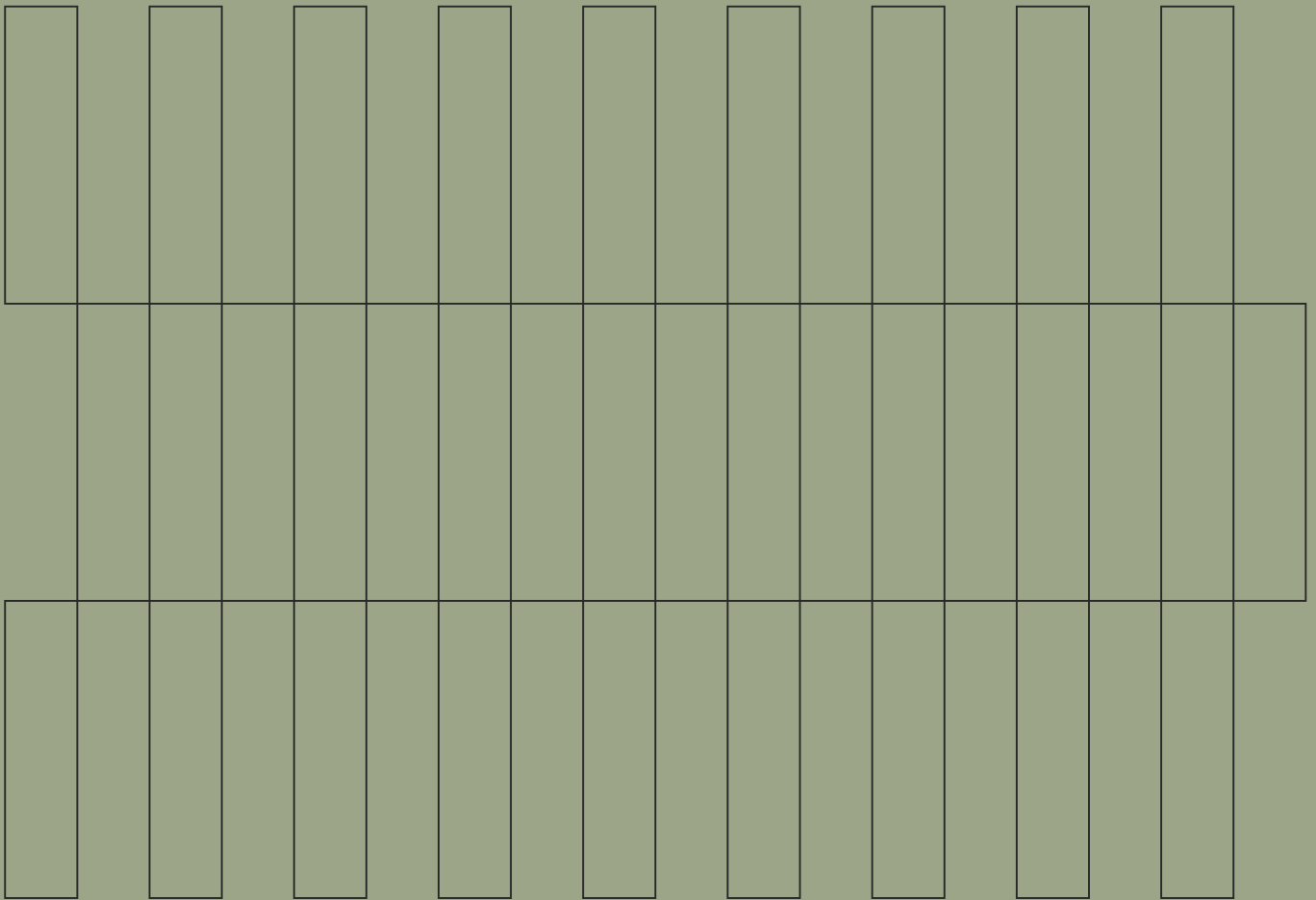

# General Internal Panelling

Installation Guide

# Installing panelling to internal walls, ceilings and out-of-weather applications including alfresco ceilings

This guide outlines basic measures that must be taken to ensure a successful installation.

## Your goal

For your internal installation of Western Red Cedar, your aim should be:

- A beautiful feature you can create yourself or have professionally installed
- Adding value and character to your home

## Tools & supplies

You'll need the following to complete this project:

- Glue and glue gun
- Drop saw with fine, sharp blade for accurate cutting without chipping
- Second fix nail gun
- Pin nails that will penetrate the framing timber at least 17mm
- Construction adhesive
- Scaffolding may be necessary

## Getting started

### 1. Prepare the wall or ceiling

- If you are attaching the internal timbers directly to the studs or ceiling battens, make sure the studs are straight and clean. If you are using 9mm thick timber, studs must be 450mm apart. All other timber thicknesses 12mm+ can span 600mm.
- If the wall panellings are to run vertically, make sure you have sufficient sturdy noggins, or the wall has horizontal battens.
- To apply timber panelling directly over plaster, find the studs and ensure the nails can fix into the studs readily. Or, fix battens over the plaster and fix the panelling to the battens.
- For concrete blocks, concrete tilt slab, or bricks, batten over the wall first. Use flush mechanical fixings, and follow the manufacturer's directions.

- For metal studs, fix battens over the studs, as you cannot readily fix each board to the metal unless a glueing technique is established.

### 2. Consider colours and lengths of the panelling

- Western Red Cedar comes in a beautiful array of colours that gives a warm ambient affect. As you install the panelling, ensure you take advantage of the colour variations in the timber boards, to achieve a satisfying visual effect.
- Prior to installing, consider the lengths that have been supplied. Plan ahead to best use these lengths to achieve even patterns and minimal wastage.
- Make sure you know which side is the face so you don't install it back to front (it has happened).

### 3. Consider pre-finished timber or DIY coating

Your options are:

- Pre-finished timber from Cedar Sales: We provide a commercial UV-cured clear or tinted finish, which is tough and scratch resistant. It's suitable for internal walls or ceilings, or external ceilings (verandahs, alfrescos, out-of-weather applications), and matching trims are available.
- DIY / onsite coating: Choose a stain, paint or clear lacquer for your timber project. Ask your paint supplier for advice

We recommend coating the back of your timber panelling before putting it up to seal the product. This gives added dimensional stability and reduces risk of water ingress from leaking roofs.

The face of the panelling can be painted before or after installation.

### 4. Glue and nail up the boards

All our internal timber panelling profiles are designed for secret nailing. This leaves no nails exposed and no holes to putty (starter boards and trims excepted). Your options are:

- a. Cut the boards very neatly so there is no need to have trim pieces to cover the edges where the panelling starts and finishes. This is considerably more difficult, but gives a very clean and impressive finish.

b. Put the boards up,

and then run a small timber bead around the full perimeter of the panelling to cover any cuts, chips and pin nails. You can choose from a multitude of different trims and coat them to match or contrast.

- Start on one side of the room, and make sure the first board is straight and square. Squeeze adhesive along the battens or studs. Place the groove side against the wall. This edge of the board may need to be shaped slightly if the wall is not straight or square. On the first board, put nails into the face of the groove side, as well as the tongue side. Each board that follows will need nails in the tongue only. Put the tongue nails in accurately so the next board covers the nail head.
- Place the second board so the groove fits firmly over the first tongue. Use glue and nails as previous.
- Continue across the ceiling or wall.
- If joins are needed, butt together carefully on a stud or batten, and glue well. At joins, take extra care

to ensure the nails do not split the tongue. See diagram below for alternative.

- When finishing on the far side, you will again need to put nails into the face of the boards. Done carefully, the only nail heads that will be visible are at the start of the wall and the finish. Cover these with a trim if you wish.

#### Note

The first and last boards can be glued in place. This will mean there are no nail holes in the first and last boards, giving a very professional finish. You will need to support those boards securely until the adhesive takes over.

- Always use a construction adhesive as well as the nails. This adds to the rigidity of the project, and reduces the chance of squeaks.

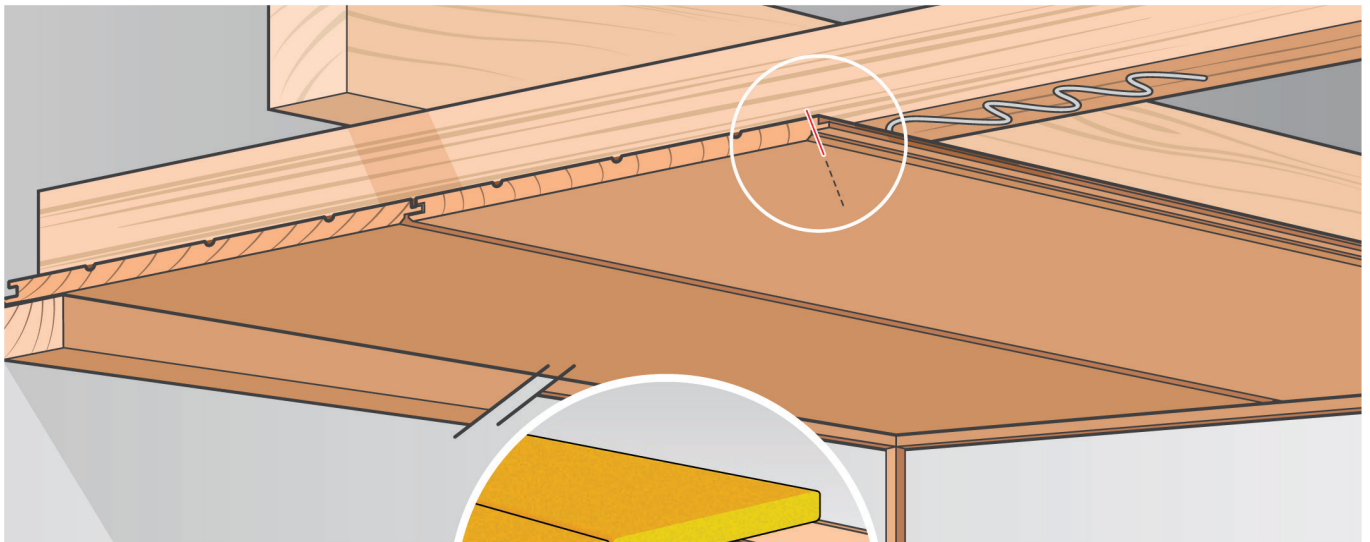

**Figure 1:** Typical ceiling installation method showing:

- Glue
- Pin nail (to be covered by next board)
- Two different sizes of trim. (DAR 18 x 18mm or DAR 31 x 18mm). You choose!

**Figure 2:** Butt joins on wall or ceiling can be placed away from battens if properly supported from behind.

## 5. Commercial ceiling installations

Timber ceilings can be readily installed where there is a metal track system.

- **Castelation® panelling with channels** can be screwed through the channel to the metal track. One screw per board, per track is sufficient (see Figure 3). This works particularly well with the Castelation® Two Tone product as the screw heads can be painted the same colour as the channels.

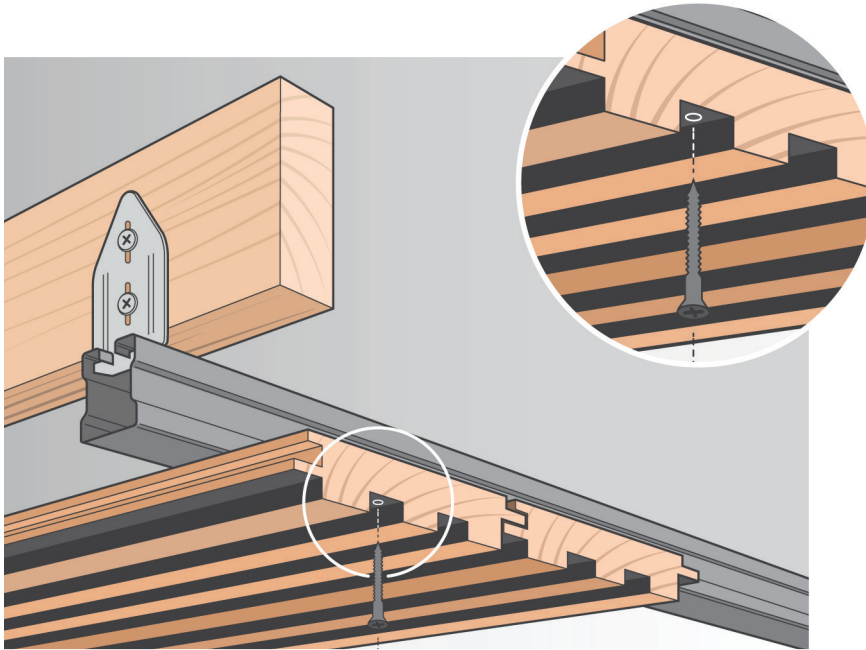

**Figure 3:** Panelling installation using metal track system and face fix; face screw directly using a coloured head screw (see Figure 4)

- For panelling that cannot use face fixing screws, it is necessary to securely scw a timber batten to the bottom of a metal track, then proceed as per timber framing projects (see Figure 4).

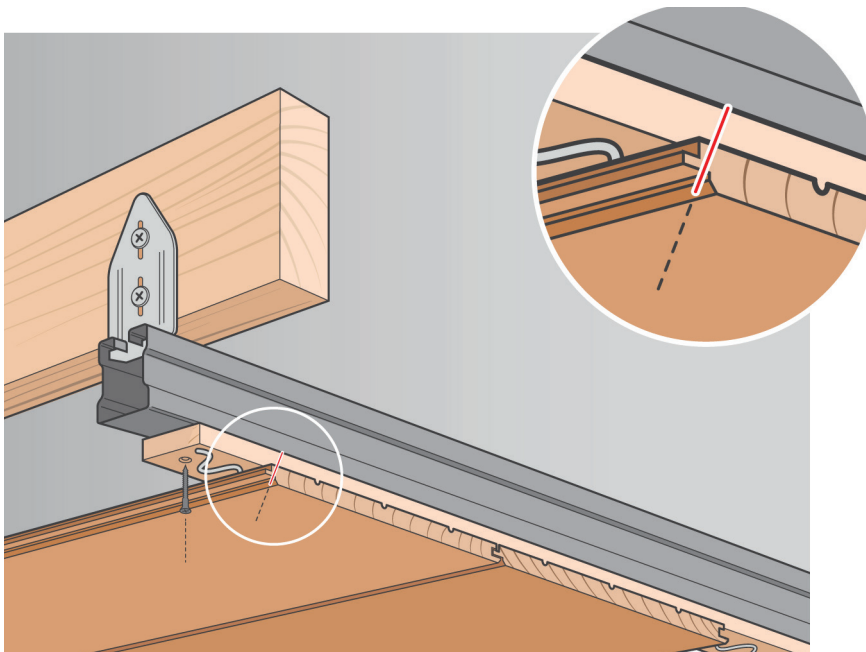

**Figure 4:** Panelling installation using metal track system / timber batten / secret nail and glue.

