

Modinex

- Timber
- Aluminium
- Concrete

Bespoke timber —
Architectural signatures



Product Catalogue

The luxurious signature in premium architectural spaces

Welcome to Modinex. We are your design innovation partners. Collaborating with architects and designers to create spaces that delight through bespoke timber architectural signatures.

At Modinex our strength is not just grounded in the unmatched beauty and sustainability of our products, it is our ability to create desire and enhance your designs with luxurious allure.



Our approach

When you specify Modinex, not only do you unlock a stunning array of innovative architectural building products, but you also experience the knowledge of 40+ years of design intelligence and practical ability Modinex has to offer. We inspire unique design opportunities, innovate the products and systems that make them possible and offer after-sales support to bring everything to life with beauty, strength, and compliance. We're passionate about bringing your creative visions to life.

Modinex environmental statement

Modinex recognises environmental responsibility as a guiding principle in our processes. At Modinex we are dedicated to minimising the impact on the environment through promoting environmental stewardship, waste, and emission reduction, and by meeting or exceeding environmental laws and regulations.

Using Modinex Long Plank process, we endeavour to utilise our shorter length timber, therefore reducing waste both in the manufacturing process and on the building site. We have fulfilled our "Zero Waste" initiative in our timber manufacturing processes, which is procured from sustainable managed forests, with PEFC Chain of Custody.

Modinex strives to continually improve and uphold its environmental performance intentions and advocate sustainability.



Table of Contents

Concrete Cladding

- 4 Viroc
- 5 Perforated Viroc

Aluminium Battens & Cladding

- 6 Alu Batten
- 8 Alu Selekt Channel
- 9 Alu Selekt Castelation

Engineered Flooring

- 10 Australia Collection
- 11 French Oak
- 13 Stair Nosings

Solid Timber Cladding & Lining

- 14 Beachclad
- 15 Elements Channel Cladding
- 16 Newport Channel Cladding
- 17 Newport Channel Charred
- 18 Nautic Cladding
- 19 Stepped Expression
- 20 Shiplap
- 21 Vee-Joint
- 22 Channel Cladding
- 24 Castelation
- 25 Screenclad
- 26 Diamond & Chamfer
- 27 Rounds
- 28 Flute & Concave
- 29 Convex
- 30 Hex Clad
- 31 Hex Clad Two Tone

Solid Timber Cladding & Lining

- 32 Castelation & Screenclad Two Tone
- 33 Venture
- 34 Aurora
- 35 Weatherboard
- 36 Shingles
- 37 Battens & Screening

Austratus Wall & Ceiling Systems

- 38 Austratus Linear
- 40 Austratus Linear DFM
- 42 Austratus Linear Infill
- 44 Austratus Grid
- 46 Austratus Grid Infill
- 48 Austratus Vertical

Decking

- 50 Millboard Decking
- 51 Tractio Decking
- 52 Instyle Decking
- 53 Pencil Round Decking

Species & Finishes

- 54 Timber Species
- 55 Timber Finishes
- 55 Timber Coatings
- 56 Aluminium Timber Grain Finishes
- 57 Solid Powder Coat Colours
- 60 Anodised Colours





Viroc

Authentic character of concrete

Size

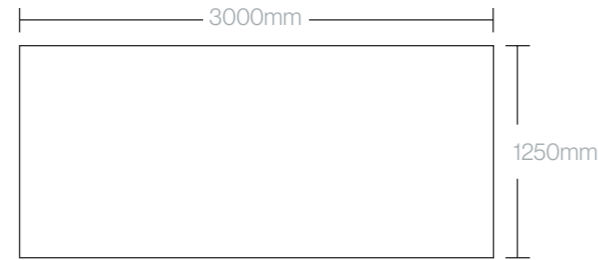

Features and Benefits

- Sheet size — 3000mm x 1250mm
- Design — Manufactured from Portland Cement, an authentic natural concrete finish is achieved
- Sustainability — Silica-free and manufactured using 100% recycled plantation PEFC Certified timber
- Application — Suitable for internal and external use
- Thickness — Available in 12mm and 19mm thickness
- Sealer — If used for flooring, benchtops, splashbacks, or externally a natural-look sealer coat is to be applied to protect from staining
- Fire rating — Group 1 internally and BAL29 externally
- Custom colours are available on request for indoor use

Colours

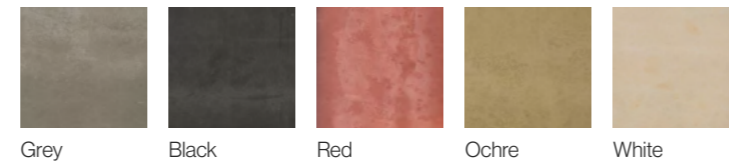

Perforated Viroc

Acoustic elegance

Size

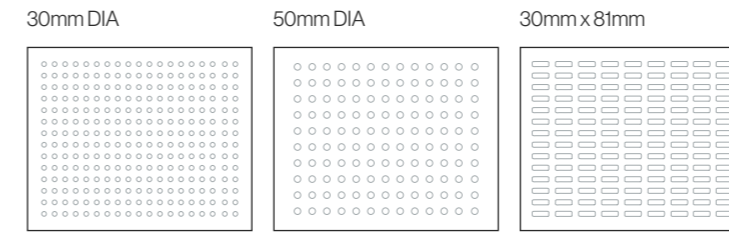
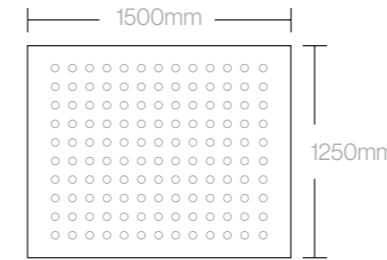

*Can be perforated according to your design preferences.

Colours

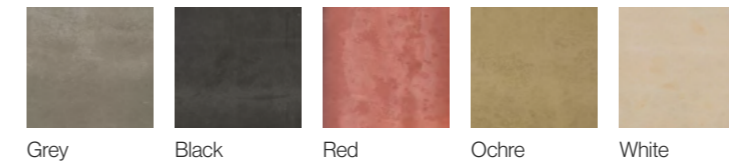

Features and Benefits

- Sheet size — 1500mm x 1250mm
- Design — Manufactured from Portland Cement, an authentic natural concrete finish is achieved
- Acoustic properties — 0.7NCR rating (may vary depending on perforation size and open space percentage)
- Sustainability — Silica-free and manufactured using 100% recycled plantation PEFC Certified timber
- Application — Internal use only
- Thickness — Available in 12mm and 19mm thickness
- Fire rating — Group 1 internally and BAL29 externally
- Custom colours are available on request for indoor use

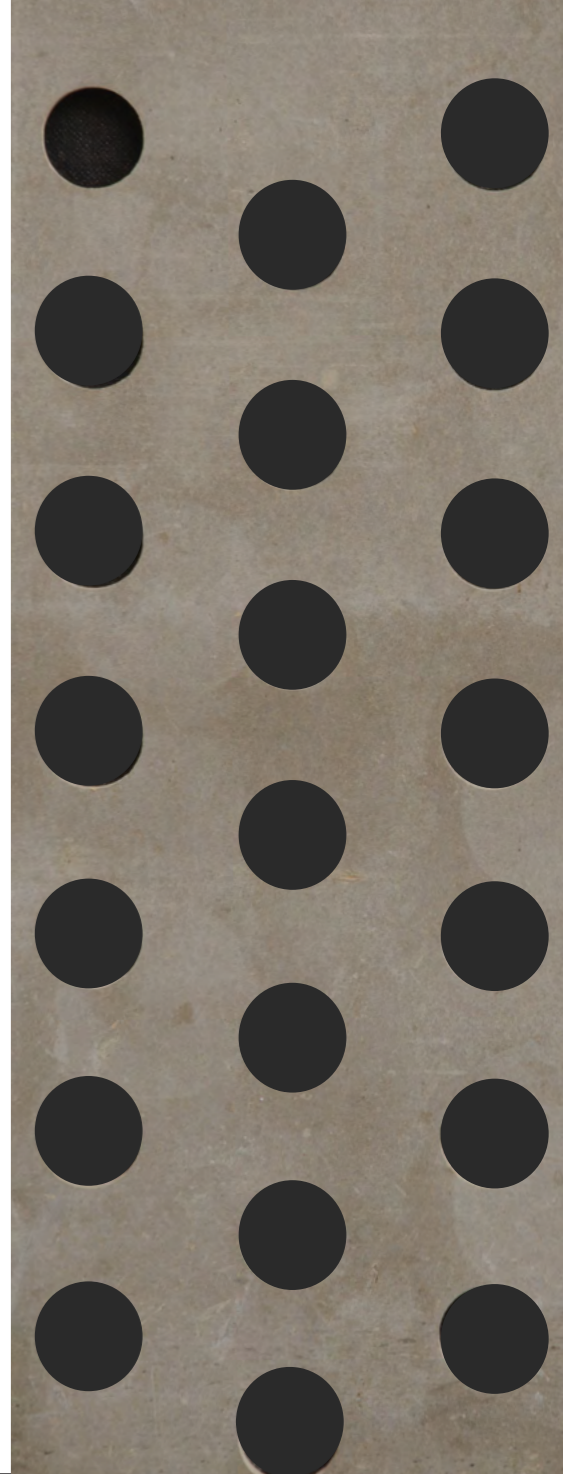
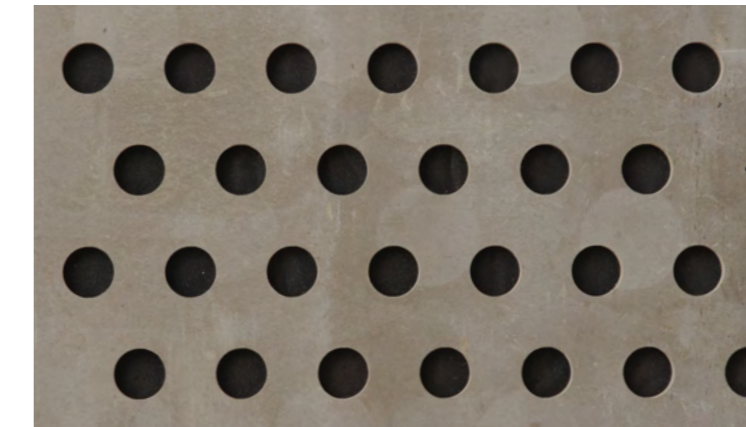

Alu Batten

Contrived for simplicity

Profiles

25mm series

25mm, 50mm, 75mm and 100mm depth available

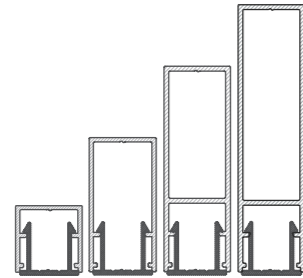

40mm series

40mm depth available

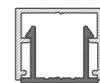

50mm series

25mm, 50mm, 100mm, 150mm and 200mm depth available

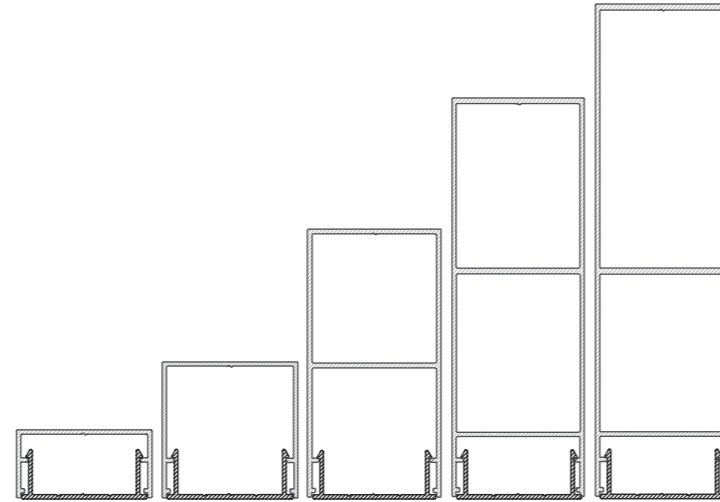

Features and Benefits

Compliance — Sea salt spray certified

Fire rating — AS1530.1 non-combustible

Durability — 25-year structural & 15-year fading warranty (if plain or timber grain powder coating finish is used)

Availability — Manufactured 100% in Australia with a short lead time

Sustainability — Available in Green & Supergreen aluminium to reduce CO2 emission by 50-75%

Design — Available in a range of plain colour or timber grain finishes

End caps — Available in a range of PVC or aluminium end caps

Finishes and Colours

— Aluminium timber grain colours listed on page 52

— Aluminium plain powder coat colours listed on page 54

— Aluminium Anodised colours listed on page 57



Alu Seleкта Channel

Confidence driven by compliance

Profiles



75mm wide
18mm thickness available

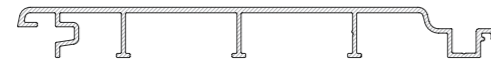

155mm wide
18mm thickness available

Features and Benefits

Compliance — CodeMark, cyclone, sea salt spray certified

Fire rating — AS1530.1 non-combustible

Durability — 25-year structural & 15-year fading warranty (if plain or timber grain powder coating finish is used)

Availability — Manufactured 100% in Australia with a short lead time

Easy to install — Concealed fixings for a refined design for ease of installation

Seamless design — Specially design interlocking tongue allows for secret fixing

Sustainability — Available in Green & Supergreen aluminium to reduce CO2 emission by 50-75%

Design — Available in a range of plain colour or timber grain finishes

Curved design — 75mm wide profile can be curved to a convex radius of 700mm and the 155mm wide profile to a convex radius of 1200mm

Finishes and Colours

— Aluminium timber grain colours listed on page 52

— Aluminium plain powder coat colours listed on page 54

— Aluminium Anodised colours listed on page 57



Alu Seleкта Castellation

Architectural elegance

Profiles



40mm wide
20mm thickness available

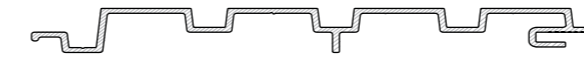

160mm wide
20mm thickness available

Features and Benefits

Compliance — CodeMark, cyclone, sea salt spray certified

Fire rating — AS1530.1 non-combustible

Durability — 25-year structural & 15-year fading warranty (if plain or timber grain powder coating finish is used)

Availability — Manufactured 100% in Australia with a short lead time

Easy to install — Concealed fixings for a refined design for ease of installation

Seamless design — Specially design interlocking tongue allows for secret fixing

Sustainability — Available in Green & Supergreen to reduce CO2 emission by 50-75%

Design — Available in a range of plain colour or timber grain finishes

Radius - 40 x 20mm profile is suitable for convex radius of 300mm or greater

Curved design — 40mm wide profile can be curved to a convex radius of 300mm

Finishes and Colours

— Aluminium timber grain colours listed on page 52

— Aluminium plain powder coat colours listed on page 54

— Aluminium Anodised colours listed on page 57





French Oak Flooring

Combining texture & tone

Plank

Thickness: 15mm & 21mm

Width: 220mm

Length: 2200mm

- In 15mm thickness, the colour Fossil Grey is a 240mm x 1900mm plank and Mink is a 220mm x 1900mm plank

- Other widths and lengths are available on request

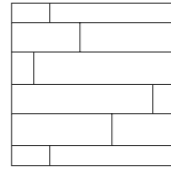

Herringbone

Thickness: 15mm

Width: 120mm

Length: 600mm

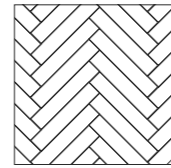

Chevron

Thickness: 15mm

Special order

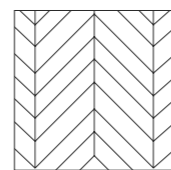

Wear Layer

Our 15mm profiles have a 4mm wear layer, and 21mm thick profiles have a 6mm thick wear layer.

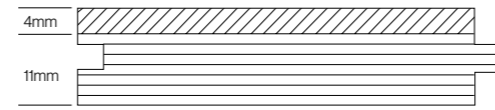

Coating

Manufactured with 8 coats of Treffert Sapphire matt for heavy duty use. Treffert Sapphire is the best performing scratch resistant coating system for flooring in the market today. This special coating system is ideally suited for surfaces in demanding environments or needing long-time guarantees.

- Non-toxic
- Two-component water based poly top coat
- Excellent wear resistance

Grading

All finishes are standard in classic grade. If a clearer grade timber with less knots or feature is required, Signature grade is available with a 12-week lead time.



Signature

Classic



Colours

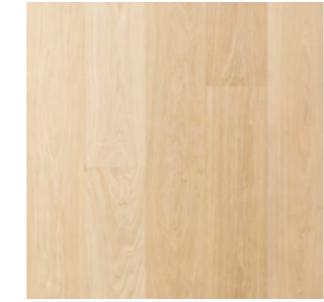

French Oak Raw

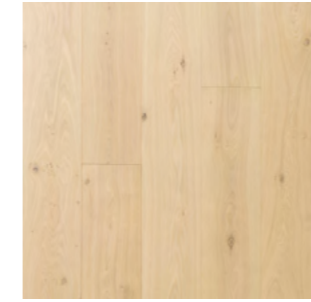

Sand Oak

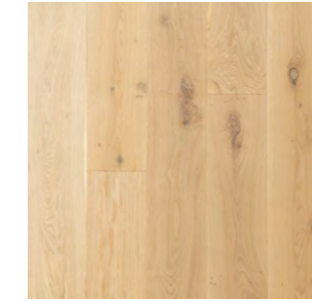

Almond



Dusk



Moonshine



Golden Haze

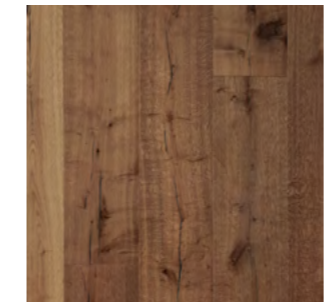

Desert Sand

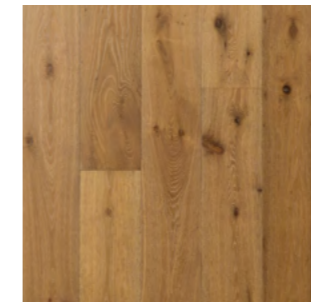

Frosted Oak



Woodland



Burnished Ash



Dark Moonstone



Mocha

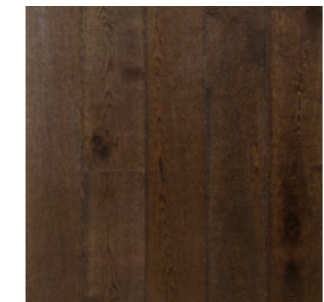

Burnt Umber



Wharf Grey

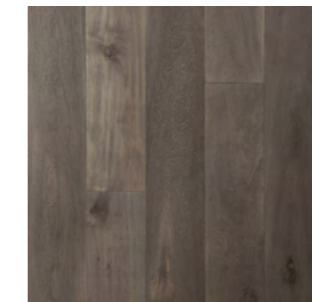

Fossil Grey



Mink



Midnight

Australian Hardwood Flooring

Authentic local character

Blackbutt



Signature

Organic

Spotted Gum



Signature

Organic

Plank

Thickness: 13.5mm

Width: 136mm & 180mm

Length: 1830mm & 2190mm

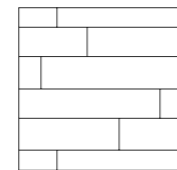

Herringbone

Thickness: 13.5mm

Width: 136mm

Length: 680mm

Only available in signature grade

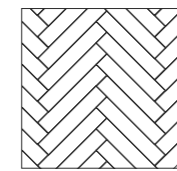

Wear Layer

Our 13.5mm profiles have a 3.5mm wear layer.

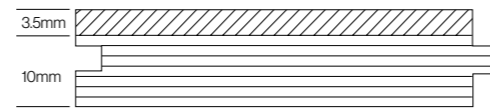

Coating

Manufactured with 8 coats of Bona Traffic ultra matt for heavy duty use giving that premium raw natural aesthetics.

- 25-year structural warranty
- Non-Toxic
- Two part water based poly coating
- Excellent wear resistance



Stair Nosings

Seamless elegance

Stair nosing range is available in our Australian Hardwood and French Oak collections. A P3 slip rating can be achieved by using perspex or metal anti-slip strips as per stair nosing 07 and 09. Insert strip colours available are light grey, walnut, black, mid grey, white, alloy and brass.

Stair Nosings

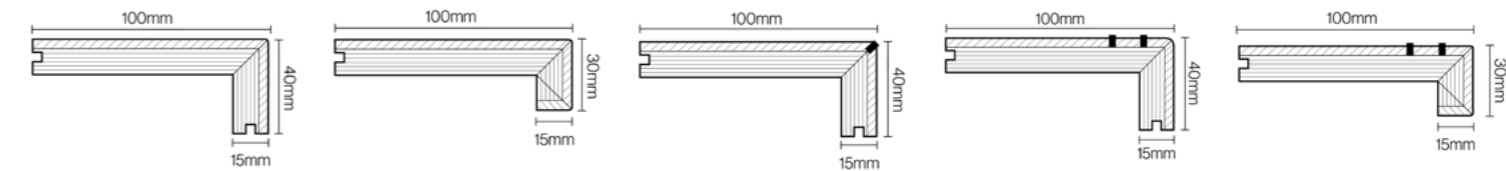

Stair Nosing 01

Stair Nosing 03

Stair Nosing 05

Stair Nosing 07

Stair Nosing 09

Enclosed Treads

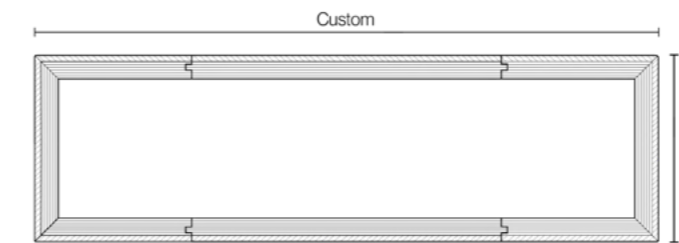







Enclosed Tread 01

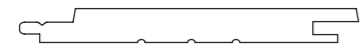

Beachclad

Rustic Weathered Charm

Profiles

 120mm wide 18mm thickness available	 40mm wide 40mm thickness available
 170mm wide 18mm thickness available	 40mm wide 60mm thickness available
 81mm wide 21mm and 25mm thickness available	 40mm wide 60mm thickness available
 115mm wide 26mm thickness available	



Features and Benefits

- Design** — Enhanced weathered character that is available in random or set length options
- Sustainable timber** — Sustainably harvested plantation timber species that is 100% PEFC Certified
- Variety in timber** — Available in four popular profiles in Knotty Grade Western Red Cedar
- Pre-finished coatings available** — Available in a range of standard colours
- Application** — Suitable for out of weather and external use

Colours





*Custom colours available on request



Elements Channel Cladding

Timeless Elegance

Profiles

 120mm wide 20mm thickness available	 40mm wide 40mm thickness available	 40mm wide 60mm thickness available
--	---	---

Features and Benefits

- Sustainable timber** — Sustainably harvested timber species that is 100% PEFC Certified and chemical free
- Variety in timber** — Available in popular profiles in Thermally Modified Hemlock timber species
- Pre-finished coatings available** — Available in a range of standard colours
- Application** — Suitable for out of weather and external use
- Durability** — High durability for external applications
- Design** — Available in random or set length options

Colours

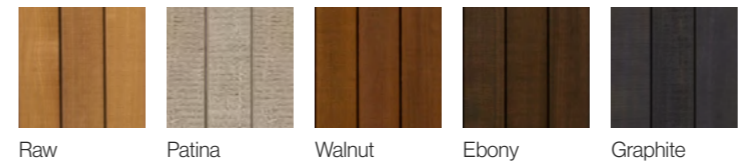

*Custom colours available on request



Newport Channel Cladding

Celebrating unique local character

Profiles

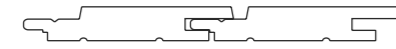

70mm wide
19mm thickness available with 5mm groove



40mm wide
40mm thickness available

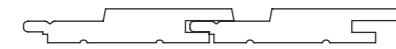

70mm wide
19mm thickness available with 15mm groove



120mm wide
19mm thickness available with 5mm groove



40mm wide
60mm thickness available

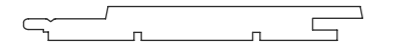

120mm wide
19mm thickness available with 15mm groove



Features and Benefits

Sustainable timber — Available in a range of sustainably certified hardwood timber species

Certification — FSC certified species are available

Fire rating — Group 3 (Group 1 if Fireshield is applied) for internal applications, and up to BAL29 for external applications (refer page 50 for further details)

Easy to install — Concealed fixings for a refined design for ease of installation

Seamless design — Specially designed interlocking tongue allows for secret fixing

Pre-finished coatings available — Available in a range of standard colours

Application — Suitable for out of weather or external use (refer page 50 for further details)

Design — Available in random or set length options

Timber Species and Colours

— Timber species listed on page 50 (Hardwoods only)

— Timber coatings listed on page 51



Newport Channel Charred

Shou Sugi Ban, embracing the charred elegance of wood

Profiles

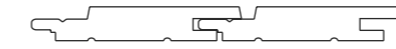

70mm wide
19mm thickness available with 5mm groove



40mm wide
40mm thickness available

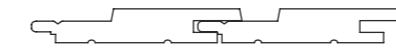

70mm wide
19mm thickness available with 15mm groove



115mm wide
26mm thickness available



120mm wide centre groove
19mm thickness available

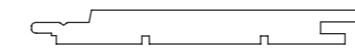

120mm wide
19mm thickness available with 5mm groove

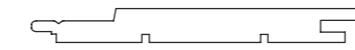

120mm wide
19mm thickness available with 15mm groove

*Other profiles available on request

Timber Species

— Timber species listed on page 50



Features and Benefits

Sustainable timber — Available in both PEFC and FSC certified Spotted Gum

Fire rating — Group 3 (Group 1 if Fireshield is applied) for internal applications, and up to BAL29 for external applications

Character — Authentic charred lizard finish

Durability — Charred finish on both sides provides for extra stability and longevity

Easy to install — Suited for concealed or face fixings for a quick and simple installation

Sealer coating — Available with one coat of our signature sealer pre applied with an additional coat required to be applied on-site once installed

Accessories — Corner stops and end trims are available

Design — Available in random or set length options



Nautic Cladding

Embracing natural beauty

Profiles

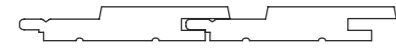

70mm wide
19mm thickness available with 15mm groove



40mm wide
40mm thickness available



120mm wide
19mm thickness available with 15mm groove



115mm wide
26mm thickness available



40mm wide
60mm thickness available

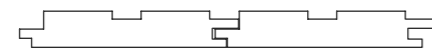

81mm x 26mm profile
21mm and 26mm thickness available



Features and Benefits

Sustainable timber — Available in a range of sustainably certified hardwood timber species

Certification — FSC certified species are available

Fire rating — Group 3 (Group 1 if Fireshield is applied) for internal applications, and up to BAL29 for external applications (refer page 50 for further details)

Easy to install — Concealed fixings for a refined design for ease of installation

Seamless design — Specially designed interlocking tongue allows for secret fixing

Pre-finished coatings available — Available in a range of standard colours

Application — Suitable for out of weather or external use (refer page 50 for further details)

Design — Enhanced weathered character that is available in random or set length options

Timber Species and Colours



Raw Charred Mist Smokey Grey

— Timber species listed on page 50 (Hardwoods only)

*Custom colours available on request



Stepped Expression

Creativity by design

Profiles

27mm wide Step series
39mm, 67mm and 91mm thickness available

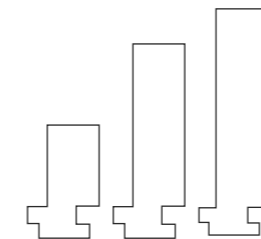

80mm wide
26mm thickness available



17mm thickness Flat series
17mm, 54mm, 81mm, 135mm, and 162mm wide available

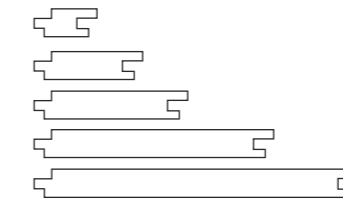

40mm wide
40mm thickness available



Timber Species and Colours

— Timber species listed on page 50

— Timber coatings listed on page 51



Features and Benefits

Sustainable timber — Available in a range of sustainably certified timber species

Configurations — Available with a range of spacer and batten profiles

Certification — PEFC and FSC certified species are available

Fire rating — Group 3 (Group 1 if Fireshield is applied) for internal applications, and up to BAL29 for external applications (refer page 50 for further details)

Easy to install — Concealed fixings for a refined design for ease of installation

Seamless design — Specially designed interlocking tongue allows for secret fixing

Design — Available in random or set length options

Pre-finished coatings available — Available in a range of standard colours

Application — Options available for external and out of weather applications





Shiplap

Timeless aesthetics

Profiles

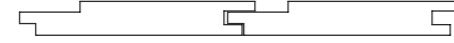

82mm wide
9mm, 12mm, 15mm and 18mm thickness available



133mm wide
9mm, 12mm, 15mm and 18mm thickness available



181mm wide
18mm thickness available



Features and Benefits

Sustainable timber — Available in a range of sustainably certified timber species

Certification — PEFC and FSC certified species are available

Fire rating — Group 3 (Group 1 if Fireshield is applied) for internal applications, and up to BAL29 for external applications (refer page 50 for further details)

Easy to install — Concealed fixings for a refined design for ease of installation

Seamless design — Specially designed interlocking tongue allows for secret fixing

Design — Available in random or set length options

Pre-finished coatings available — Available in a range of standard colours

Application — Options available for external and out of weather applications

Timber Species and Colours

— Timber species listed on page 50

— Timber coatings listed on page 51



Vee-joint

Minimalistic design

Profiles

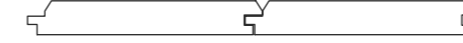

86mm wide
9mm, 12mm, 15mm and 18mm thickness available



133mm wide
12mm, 15mm and 18mm thickness available



136mm wide
9mm thickness available



181mm wide
18mm thickness available

Timber Species and Colours

— Timber species listed on page 50

— Timber coatings listed on page 51



Features and Benefits

Sustainable timber — Available in a range of sustainably certified timber species

Certification — PEFC and FSC certified species are available

Fire rating — Group 3 (Group 1 if Fireshield is applied) for internal applications, and up to BAL29 for external applications (refer page 50 for further details)

Easy to install — Concealed fixings for a refined design for ease of installation

Seamless design — Specially designed interlocking tongue allows for secret fixing

Design — Available in random or set length options

Pre-finished coatings available — Available in a range of standard colours

Application — Options available for external and out of weather applications



Channel Cladding

Simplistic timeless character

Profiles

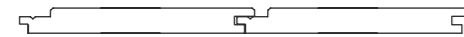

86mm wide
12mm thickness available

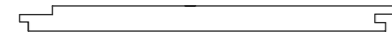

133mm wide
12mm thickness available

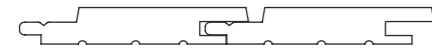

70mm wide
18mm thickness available



120mm wide
18mm thickness available



170mm wide
18mm thickness available



115mm wide
26mm thickness available

Features and Benefits

Sustainable timber — Available in a range of sustainably certified timber species

Certification — PEFC and FSC certified species are available

Fire rating — Group 3 (Group 1 if Fireshield is applied) for internal applications, and up to BAL29 for external applications (refer page 50 for further details)

Easy to install — Concealed fixings for a refined design for ease of installation

Seamless design — Specially designed interlocking tongue allows for secret fixing

Design — Available in random or set length options

Pre-finished coatings available — Available in a range of standard colours

Application — Options available for external and out of weather applications

Timber Species and Colours

— Timber species listed on page 50

— Timber coatings listed on page 51





Castelation

A iconic form of architecture

Profiles



81mm wide
12mm and 18mm thickness available



81mm wide
21mm and 26mm thickness available



Features and Benefits

Sustainable timber — Available in a range of sustainably certified timber species

Certification — PEFC and FSC certified species are available

Fire rating — Group 3 (Group 1 if Fireshield is applied) for internal applications, and up to BAL29 for external applications (refer page 50 for further details)

Easy to install — Concealed fixings for a refined design for ease of installation

Seamless design — Specially designed interlocking tongue allows for secret fixing

Design — Available in random or set length options

Pre-finished coatings available — Available in a range of standard colours

Application — Options available for external and out of weather applications

Timber Species and Colours

— Timber species listed on page 50

— Timber coatings listed on page 51



Screenclad

Natural linear elegance

Profiles

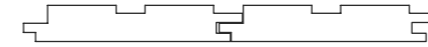

81mm wide
12mm, and 18mm thickness available



81mm wide
21mm and 26mm thickness available



120mm wide
21mm and 26mm thickness available

Timber Species and Colours

— Timber species listed on page 50

— Timber coatings listed on page 51



Features and Benefits

Sustainable timber — Available in a range of sustainably certified timber species

Certification — PEFC and FSC certified species are available

Fire rating — Group 3 (Group 1 if Fireshield is applied) for internal applications, and up to BAL29 for external applications (refer page 50 for further details)

Easy to install — Concealed fixings for a refined design for ease of installation

Seamless design — Specially designed interlocking tongue allows for secret fixing

Design — Available in random or set length options

Pre-finished coatings available — Available in a range of standard colours

Application — Options available for external and out of weather applications



Diamond & Chamfer

Derived from sculptural shapes and forms

Profiles

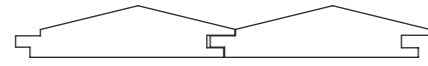

Diamond Clad Single 81mm wide
26mm thickness available

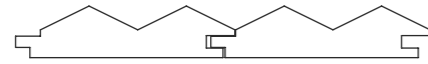

Diamond Clad Double 81mm wide
26mm thickness available



Diamond Clad 81mm wide
26mm thickness available

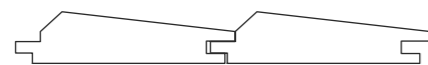

Chamfer Clad 81mm wide
26mm thickness available

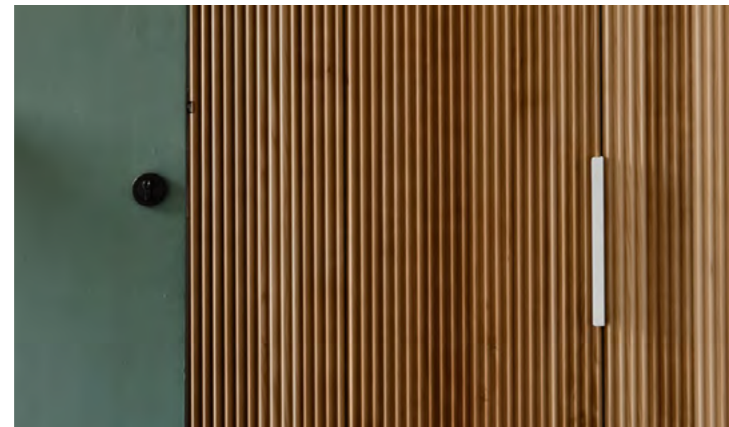

Features and Benefits

Sustainable timber — Available in a range of sustainably certified timber species

Certification — PEFC and FSC certified species are available

Fire rating — Group 3 (Group 1 if Fireshield is applied) for internal applications, and up to BAL29 for external applications (refer page 50 for further details)

Easy to install — Concealed fixings for a refined design for ease of installation

Seamless design — Specially designed interlocking tongue allows for secret fixing

Design — Available in random or set length options

Pre-finished coatings available — Available in a range of standard colours

Application — Options available for external and out of weather applications

Timber Species and Colours

— Timber species listed on page 50

— Timber coatings listed on page 51



Rounds

Embracing biophilic forms

Profiles

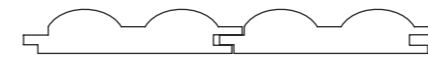

Double round 81mm wide
26mm thickness available



Half Dowel 81mm wide
26mm thickness available

Timber Species and Colours

— Timber species listed on page 50

— Timber coatings listed on page 51



Features and Benefits

Sustainable timber — Available in a range of sustainably certified timber species

Certification — PEFC and FSC certified species are available

Fire rating — Group 3 (Group 1 if Fireshield is applied) for internal applications, and up to BAL29 for external applications (refer page 50 for further details)

Easy to install — Concealed fixings for a refined design for ease of installation

Seamless design — Specially designed interlocking tongue allows for secret fixing

Design — Available in random or set length options

Pre-finished coatings available — Available in a range of standard colours

Application — Options available for external and out of weather applications





Flute & Concave

Enhancing spaces through biophilia

Profiles

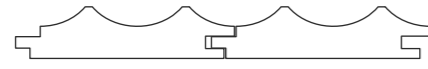

Flute 81mm wide
26mm thickness available

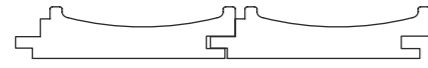

CNCV 81mm wide
26mm thickness available

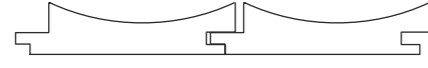

RCV 81mm wide
26mm thickness available

Features and Benefits

Sustainable timber — Available in a range of sustainably certified timber species

Certification — PEFC and FSC certified species are available

Fire rating — Group 3 (Group 1 if Fireshield is applied) for internal applications, and up to BAL29 for external applications (refer page 50 for further details)

Easy to install — Concealed fixings for a refined design for ease of installation

Seamless design — Specially designed interlocking tongue allows for secret fixing

Design — Available in random or set length options

Pre-finished coatings available — Available in a range of standard colours

Application — Options available for external and out of weather applications



Timber Species and Colours

— Timber species listed on page 50

— Timber coatings listed on page 51



Convex

Sustainable timeless beauty

Profiles

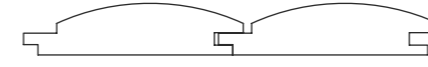

RCX 81mm wide
26mm thickness available

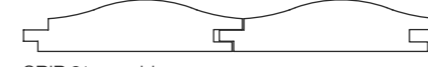

SRIB 81mm wide
26mm thickness available



Ribclad 81mm wide
26mm thickness available

Features and Benefits

Sustainable timber — Available in a range of sustainably certified timber species

Certification — PEFC and FSC certified species are available

Fire rating — Group 3 (Group 1 if Fireshield is applied) for internal applications, and up to BAL29 for external applications (refer page 50 for further details)

Easy to install — Concealed fixings for a refined design for ease of installation

Seamless design — Specially designed interlocking tongue allows for secret fixing

Design — Available in random or set length options

Pre-finished coatings available — Available in a range of standard colours

Application — Options available for external and out of weather applications

Timber Species and Colours

— Timber species listed on page 50

— Timber coatings listed on page 51

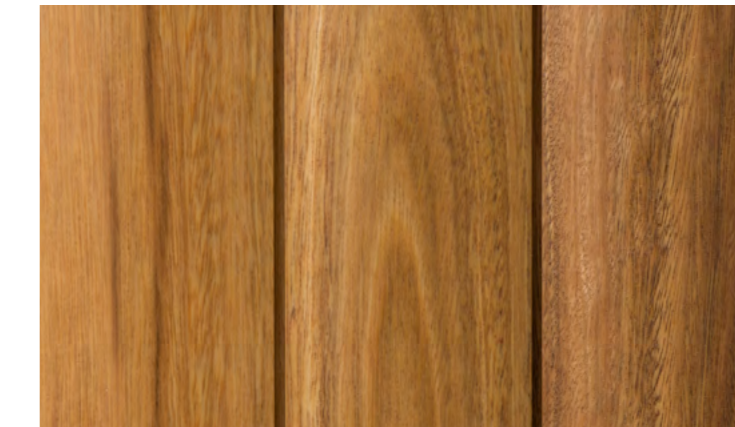

Hex Clad

Imparting a geometric aesthetic

Profiles

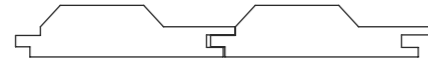

Single 81mm wide
26mm thickness available

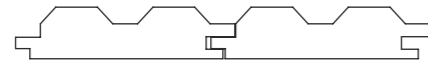

Double 81mm wide
21mm and 26mm thickness available

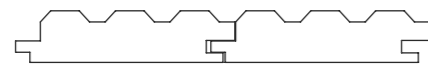

Triple 81mm wide
21mm and 26mm thickness available

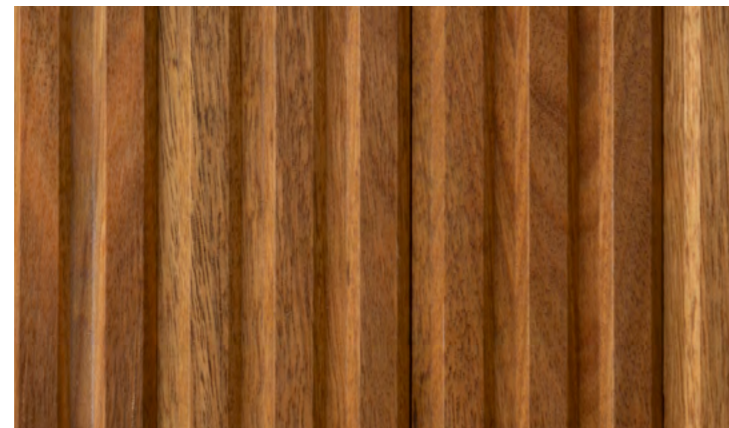

Features and Benefits

Sustainable timber — Available in a range of sustainably certified timber species

Certification — PEFC and FSC certified species are available

Fire rating — Group 3 (Group 1 if Fireshield is applied) for internal applications, and up to BAL29 for external applications (refer page 50 for further details)

Easy to install — Concealed fixings for a refined design for ease of installation

Seamless design — Specially designed interlocking tongue allows for secret fixing

Design — Available in random or set length options

Pre-finished coatings available — Available in a range of standard colours

Application — Options available for external and out of weather applications

Timber Species and Colours

— Timber species listed on page 50

— Timber coatings listed on page 51



Hex Clad Two Tone

Exudes modernity and distinctive flair

Profiles

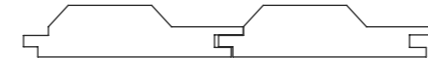

Single 81mm wide
26mm thickness available

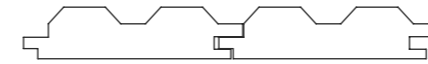

Double 81mm wide
21mm and 26mm thickness available



Triple 81mm wide
21mm and 26mm thickness available

Timber Species and Colours



Black Cognac Mangrove Evening Haze

— Timber species listed on page 50

*Custom RAL colours are available



Suitable for out-of-weather use only

Features and Benefits

Sustainable timber — Available in a range of sustainably certified timber species

Design — Available in random or set length options

Certification — PEFC and FSC certified species are available

Fire rating — Group 3 (Group 1 if Fireshield is applied) for internal applications, and up to BAL29 for external applications (refer page 50 for further details)

Easy to install — Concealed fixings for a refined design for ease of installation

Seamless design — Specially designed interlocking tongue allows for secret fixing

Pre-finished coatings available — Available in a range of standard colours

Application — Suitable for internal and out of weather applications only

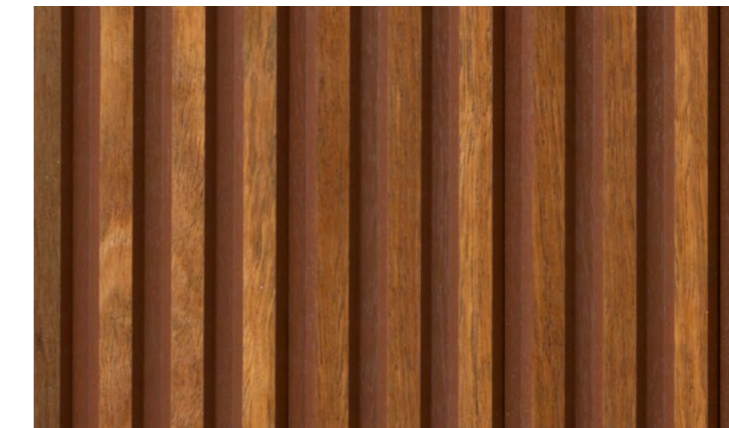



Castelation & Screenclad Two Tone

Defined luxury and sophistication

Profiles



Castelation 81mm wide
12mm and 18mm thickness available



Castelation 81mm wide
21mm and 26mm thickness available

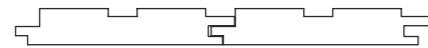

Screenclad 81mm wide
12mm and 18mm thickness available



Screenclad 81mm wide
21mm and 26mm thickness available

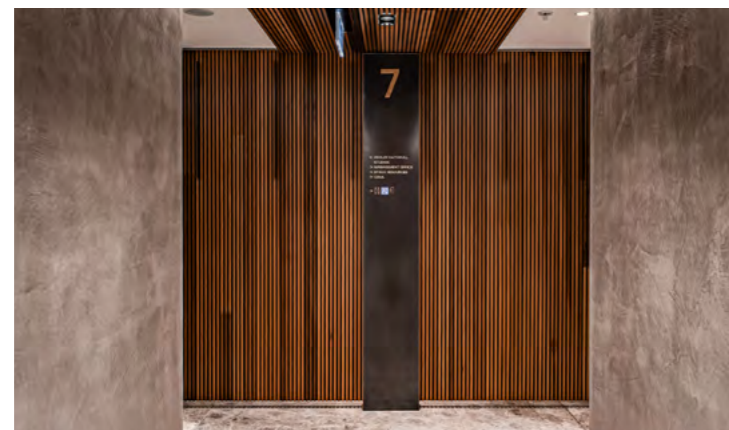

Features and Benefits

Sustainable timber — Available in a range of sustainably certified timber species

Certification — PEFC and FSC certified species are available

Fire rating — Group 3 (Group 1 if Fireshield is applied) for internal applications, and up to BAL29 for external applications (refer page 50 for further details)

Easy to install — Concealed fixings for a refined design for ease of installation

Seamless design — Specially designed interlocking tongue allows for secret fixing

Design — Available in random or set length option

Pre-finished coatings available — Available in a range of standard colours

Application — Suitable for internal and out of weather applications only

Timber Species and Colours



Mocha Sago Double Black Double White

— Timber species listed on page 50

*Custom RAL colours are available



Suitable for out-of-weather use only



Venture

Enhancing the beauty of timber

Profiles

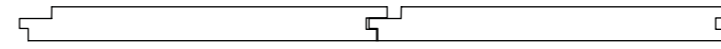

133mm wide
12mm thickness available

Features and Benefits

Sustainable timber — Available in a range of sustainably certified timber species.

Certification — 100% plantation PEFC Certified

Fire rating — Group 3 (Group 1 if Fireshield is applied) for internal applications

Easy to install — Concealed fixings for a refined design for ease of installation

Seamless design — Specially designed interlocking tongue allows for secret fixing

Design — Available in random or set length options

Pre-finished coatings available — Available in a range of standard colours

Application — Suitable for internal and out of weather applications only

Timber Species and Colours



Raven Coal Dove Ivory



Suitable for out-of-weather use only

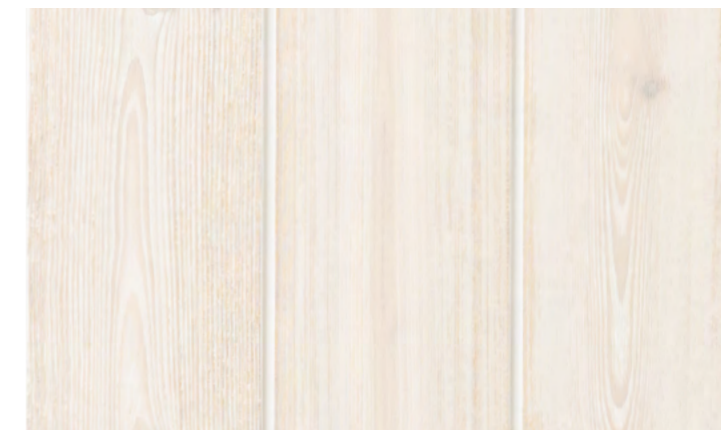



Aurora

Amplifying natural beauty

Profiles



133mm wide
12mm thickness available



Features and Benefits

- Sustainable timber — Available in a range of sustainably certified timber species
- Certification — PEFC and FSC certified species are available
- Available in both random or set length options
- Pre-finished coatings available — Available in a range of standard colours
- Application — Suitable for internal and out of weather applications only

Timber Species and Colours

- Timber species listed on page 50
- *Only available in species Hemlock, Western Red Cedar and Western Red Cedar Tight Knot



Weatherboard

Enhancing aesthetics and structural durability

Profiles



130mm wide (110 cover)
18mm thickness available

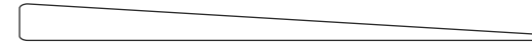

180mm wide (160 cover)
18mm thickness available

Timber Species

- Timber species listed on page 50
- Timber coatings listed on page 51



Features and Benefits

- Sustainable timber — Manufactured from 100% plantation PEFC Certified Western Red Cedar Tight Knot species
- Application — Suitable for external use
- Installation — Simple cost-effective installation

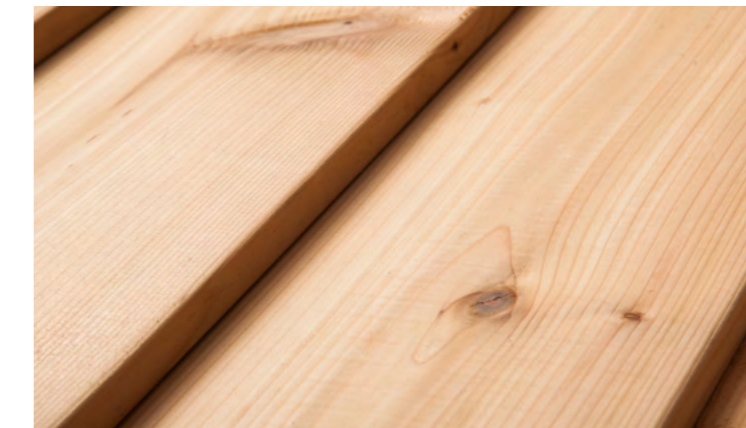

Shingles

Elevating design and exquisite craftsmanship

Profiles

450mm wide
11mm thickness available

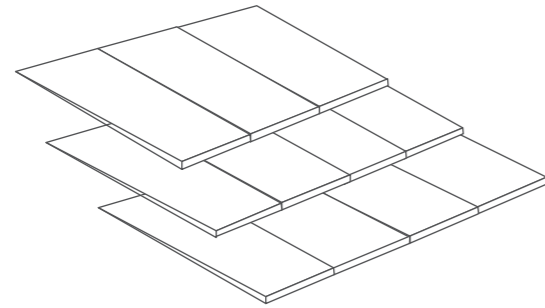

Features and Benefits

Sustainable timber — Manufactured from 100% plantation PEFC Certified Western Red Cedar

Durability — Highly durable and manufactured from Western Red Cedar

Application — Suitable for external use



Battens & Screening

Sleek simplicity

Profiles

30mm wide series
30mm, 40mm, 67mm
and 91mm thickness available

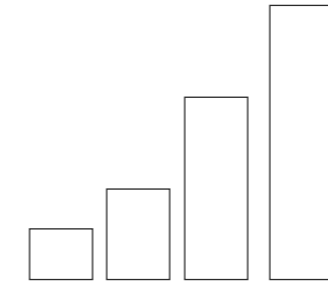

40mm wide series
40mm, 67mm and 91mm
thickness available

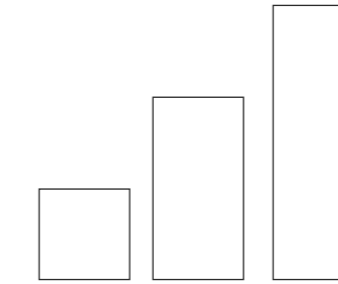

Features and Benefits

Sustainable timber — Available in a range of sustainably certified softwood and hardwood timber species

Application — Options available for external and out of weather applications

Design — Available in random or set length options. Also a range of surface finishes are available. Please refer to page 51

Timber Species and Colours

— Timber species listed on page 50

— Timber coatings listed on page 51



Austratus Linear

Architectural charm

Profiles

30mm Fin series

30mm, 40mm, 60mm, 90mm, 140mm and 190mm depth available



30mm V Fin
60mm depth available

Dome series
40mm, 60mm and 90mm depth available

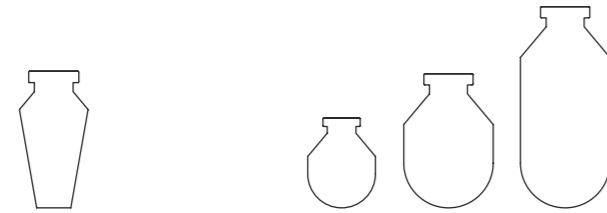

Flat series

29mm, 40mm, 60mm and 90mm wide available

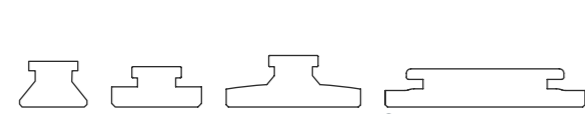

40mm Fin series

40mm, 60mm, 90mm, 140mm and 190mm depth available

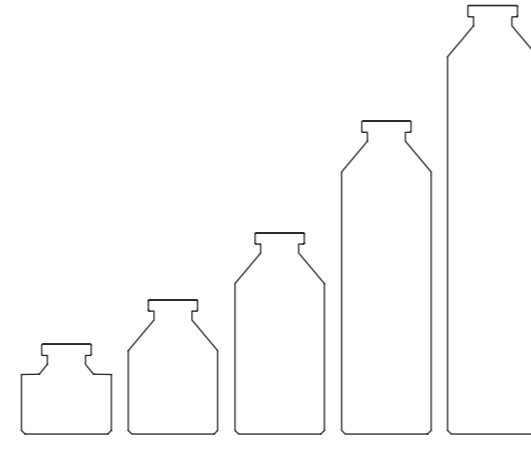

42mm Peak series
40mm, 60mm and 90mm wide available

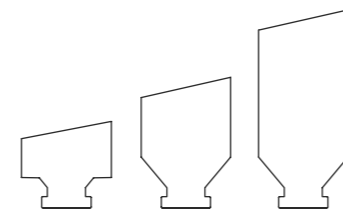

30mm Concave
60mm wide available

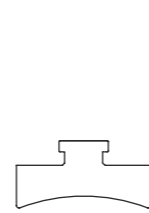

Dowel series

32mm, 40mm and 60mm width available

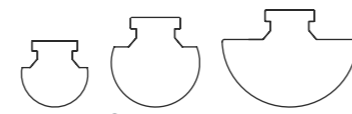

Features and Benefits

Acoustic — Up to 0.9 NCR acoustic rated insulation available

Fire rating — Up to BAL 29 or Group 3 fire-rated timber species available (Group 1 if Fireshield coating is applied) and aluminium profiles are AS1530.1 non-combustible or Group 1 fire rated

Sustainability — Profiles are available in a large range of sustainable timber species or in aluminium (Green or Super Green to reduce CO2 emission by 50-75%)

Pre-finished — Available in a range of standard or custom pre-finished stains, colours and powder coat finishes

Application — Suitable for out of weather or external use

Elevation View



Plan View

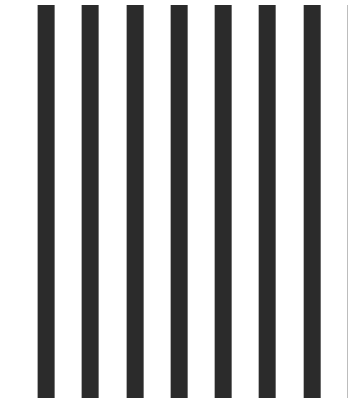

Materials and Colours

— Timber species listed on page 50. Hardwood species are only suitable for profiles up to 140mm of depth

— Timber coatings listed on page 51

— Aluminium timber grain colours listed on page 52

— Aluminium plain powder coat colours listed on page 54

— Aluminium Anodised colour listed on page 57

— Profiles available in aluminium are marked with the  symbol below them



Austratus Linear DFM (Direct Fix)

Simplistic creativity

Profiles

30mm Fin series

30mm, 40mm, 60mm, 90mm, 140mm and 190mm depth available



30mm V Fin
60mm depth available

Dome series
40mm, 60mm and 90mm depth available

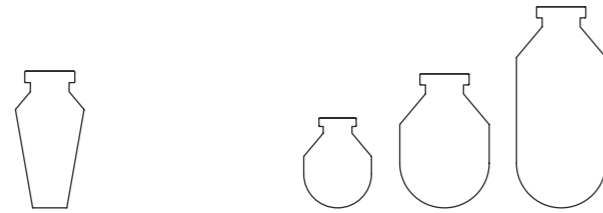

Flat series

29mm, 40mm, 60mm and 90mm wide available

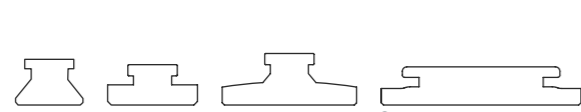

40mm Fin series

40mm, 60mm, 90mm, 140mm and 190mm depth available



42mm Peak series
40mm, 60mm and 90mm wide available

30mm Concave
60mm wide available

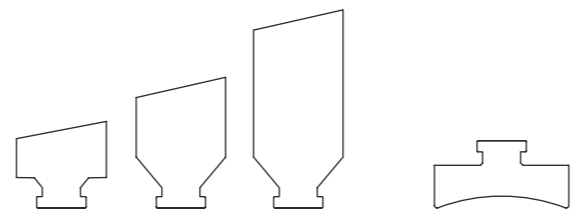

Dowel series

32mm, 40mm and 60mm width available

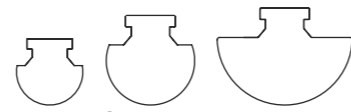

Features and Benefits

Acoustic — Up to 0.9NCR acoustic rated insulation available

Fire rating — Up to BAL 29 or Group 3 fire-rated timber species available (Group 1 if Fireshield coating is applied) and aluminium profiles are AS1530.1 non-combustible or Group 1 fire rated

Sustainability — Profiles are available in a large range of sustainable timber species or in aluminium (Green or Super Green to reduce CO2 emission by 50-75%)

Pre-finished — Available in a range of standard or custom pre-finished stains, colours and powder coat finishes

Application — Suitable for out of weather or external use

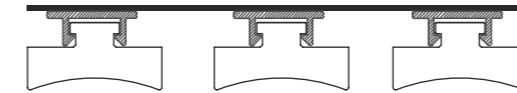

Elevation View



Plan View

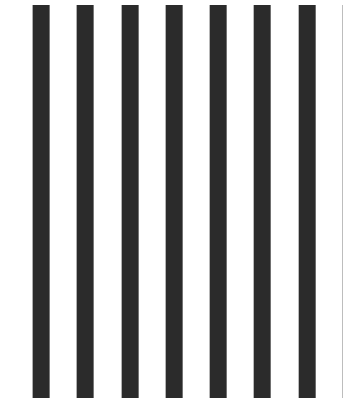

Materials and Colours

— Timber species listed on page 50. Hardwood species are only suitable for profiles up to 140mm of depth

— Timber coatings listed on page 51

— Aluminium timber grain colours listed on page 52

— Aluminium plain powder coat colours listed on page 54

— Aluminium Anodised colour listed on page 57

— Profiles available in aluminium are marked with the  symbol below them



Austratus Linear Infill

Linear sophistication

Profiles

30mm wide Top Mount
40mm, 60mm and 90mm depth available

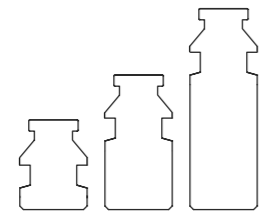

Installation Example

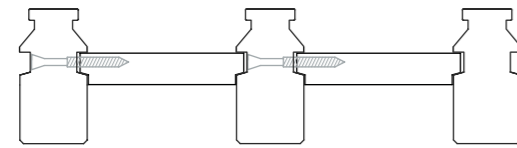

90mm wide Infill
18mm thickness available



30mm wide Bottom Mount
40mm, 60mm and 90mm depth available

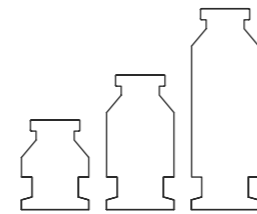

Installation Example

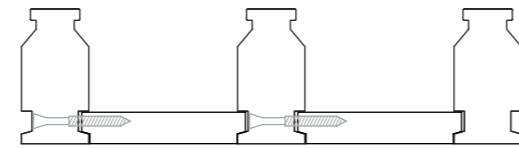

Features and Benefits

Design — The ideal design solution for a solid timber ceiling with interchangeable batten styles and infill, also being able to be integrated with the Austratus Linear collection

Fire rating — Timber profiles are up to BAL29 or Group 3 fire-rated (Group 1 if Fireshield is applied)

Sustainability — Profiles are available in a large range of sustainable timber species

Pre-finished coatings — Available in a range of standard or custom pre-finished stains and colours

Application — Suitable for out of weather or external use

Elevation View



Plan View

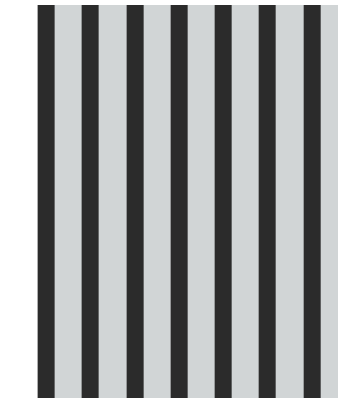

Materials and Colours

— Timber species listed on page 50

— Timber coatings listed on page 51

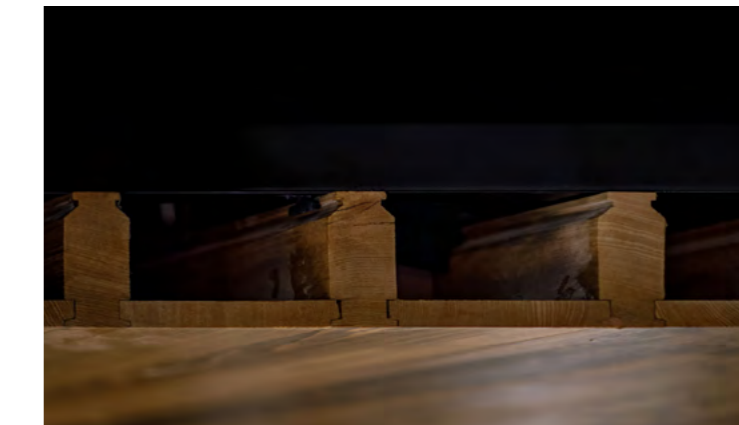



Austratus Grid

Features of creativity

Profiles

30mm Fin series

40mm, 60mm, 90mm, 140mm and 190mm depth available



30mm Facia

65mm, 85mm, 115mm, 165mm and 215mm depth available

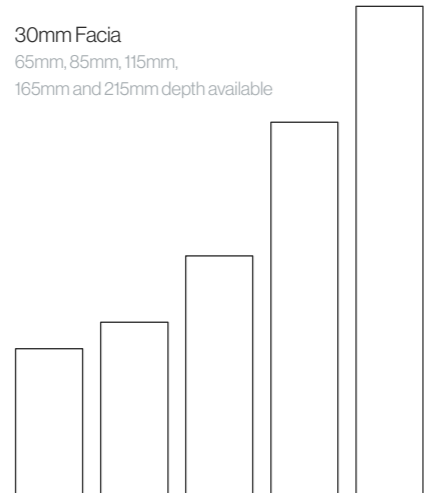

40mm Fin series

40mm, 60mm, 90mm, 140mm and 190mm depth available

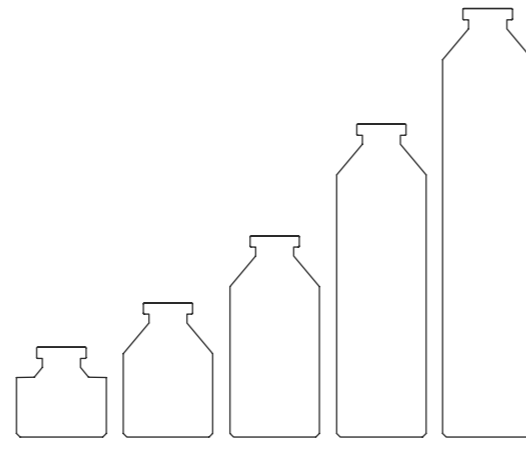

40mm Facia

65mm, 85mm, 115mm, 165mm and 215mm depth available

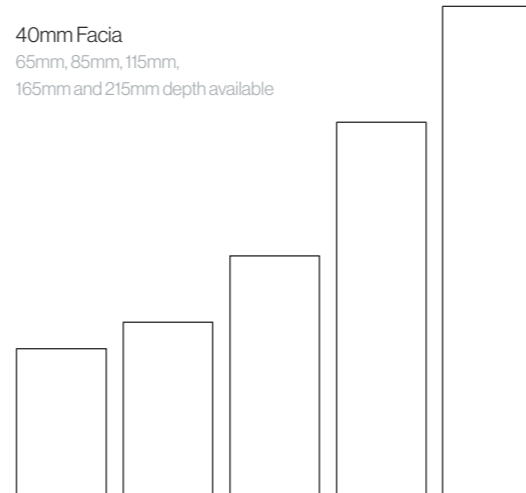

Features and Benefits

Design — Suspended grid ceiling solution, designed for quick and ease of installation

Fire rating — Up to BAL 29 or Group 3 fire-rated timber species available (Group 1 if Fireshield coating is applied) and aluminium profiles are AS1530.1 non-combustible or Group 1 fire rated

Sustainability — Available in Green & Supergreen aluminium to reduce CO2 emission by 50-75% or a large range of sustainable timber species

Pre-finished coatings — Available in a range of standard colours

Application — Suitable for internal and out of weather applications only

Grid size — Softwood species are suitable for a grid size of up to 1m x 1m. However, Hardwood species are only suitable for up to 0.6m x 0.6m and a max batten depth of 140mm

Elevation View



Plan View

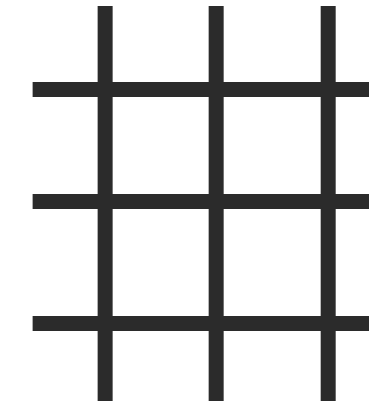

Materials and Colours

— Timber species listed on page 50. Hardwood species are only suitable for profiles up to 140mm of depth

— Timber coatings listed on page 51

— Aluminium timber grain colours listed on page 52

— Aluminium plain powder coat colours listed on page 54

— Aluminium Anodised colour listed on page 57

— Profiles available in aluminium are marked with the • symbol below them





Austratus Grid Infill

Creativity with an ease of installation

Profiles

40mm Fin series

42mm, 92mm, 142mm and 190mm depth available

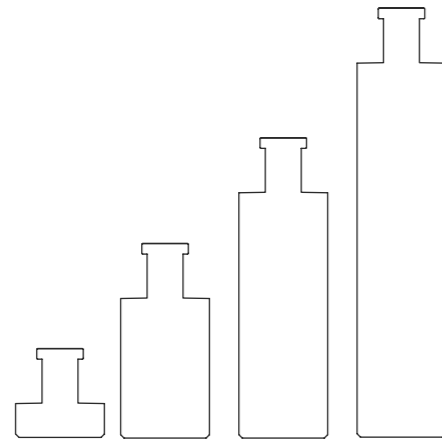

40mm Facia

67mm, 117mm, 167mm and 215mm depth available

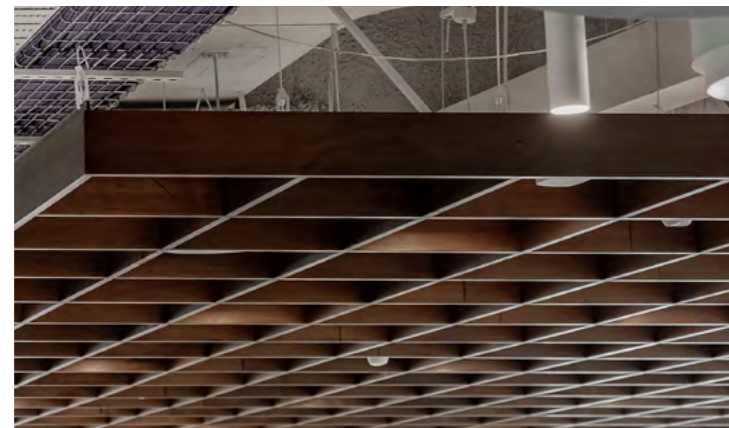
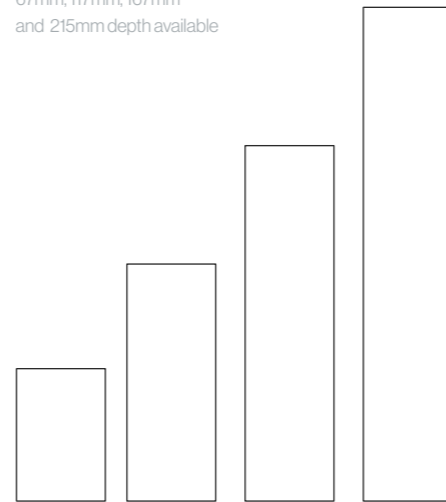

Features and Benefits

Design — Suspended grid infill ceiling solution, designed for quick and ease of installation. Available with a range of infill options, powder coated mesh, acoustic tiles and veneer panels

Grid size — Softwood species are suitable for a grid size of up to 1m x 1m. However, Hardwood species are only suitable for up to 0.6m x 0.6m and a max batten depth of 140mm

Fire rating — Group 3 (Group 1 if Fireshield is applied) internally

Pre-finished coatings — Available in a range of standard colours

Application — Suitable for internal and out of weather applications only

Elevation View



Plan View

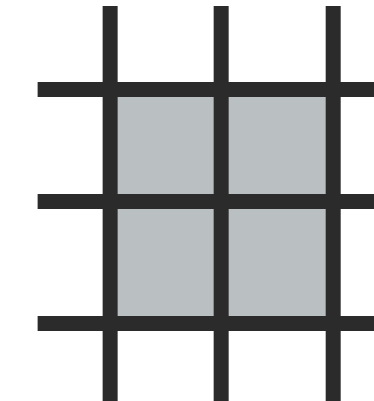

Materials and Colours

— Timber species listed on page 50

— Timber coatings listed on page 51

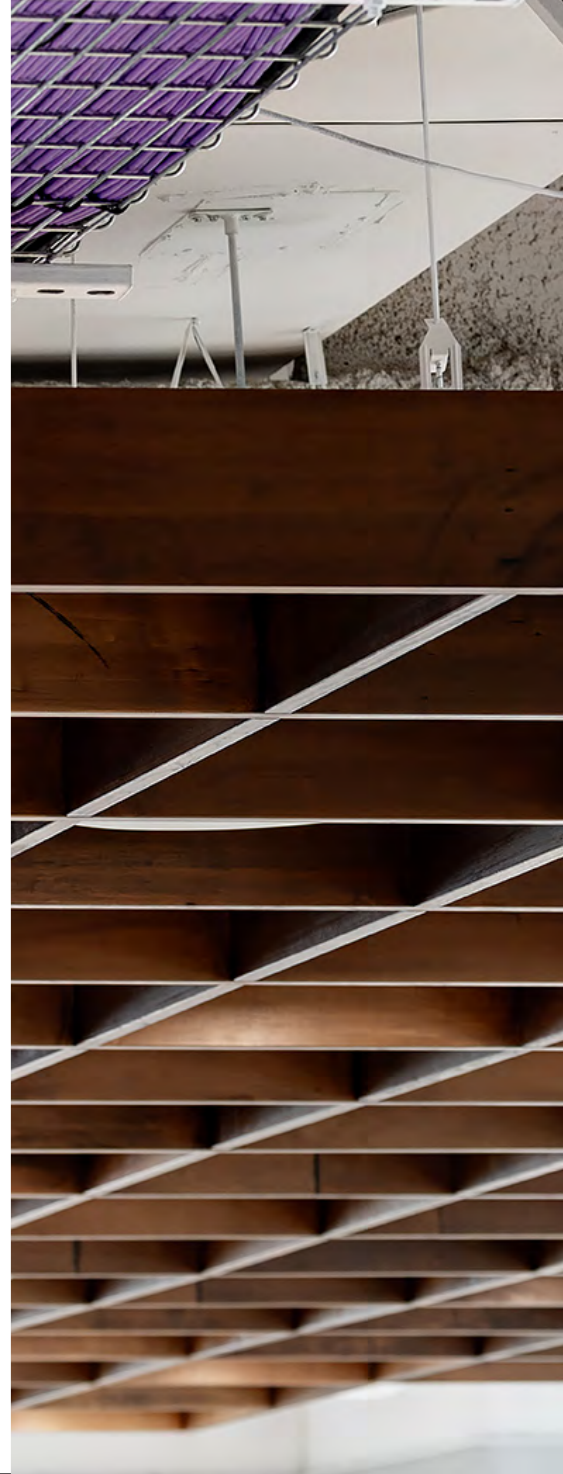



Austratus Vertical

Gravitational sophistication

Profiles

40mm Square
 Any custom lengths available from 500mm to 1000mm long.
 Available with square or 10mm radius corners



Features and Benefits

Design — Suspended vertical ceiling solution, designed for quick and ease of installation

Fire rating — Group 3 (Group 1 if Fireshield is applied) internally

Sustainability — Large range of 100% plantation PEFC certified softwood species available

Timber species — Only available in Western Red Cedar, Alaskan Cedar, and Hemlock timber species

Pre-finished coatings — Available in a range of standard colours

Application — Suitable for internal and out of weather applications only

Plan View

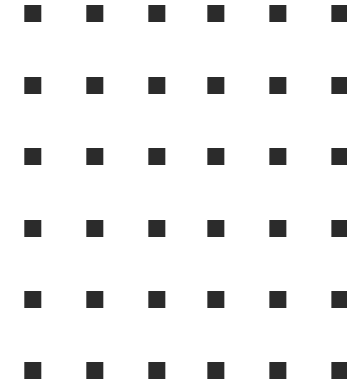

Elevation View



Materials and Colours

— Timber species listed on page 50

— Timber coatings listed on page 51





Millboard Decking

Meticulously engineered to replicate the natural beauty of timber

Profiles



Bullnose 50mm wide (3.2 metre)
33mm thickness available



Fascia 146mm wide (3.2 metre)
18mm thickness available



Decking 176mm wide (3.6 metre)
32mm thickness available



Decking 200mm wide (3.6 metre)
32mm thickness available



Features and Benefits

Fire rating — BAL19 fire rating

Compliance — P5 slip rating

Durability — 25-year structural & 15-year fading warranty

Colours

— Enhanced Grain

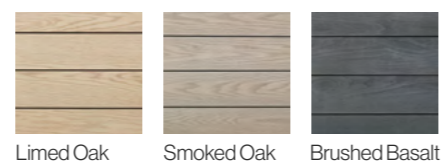
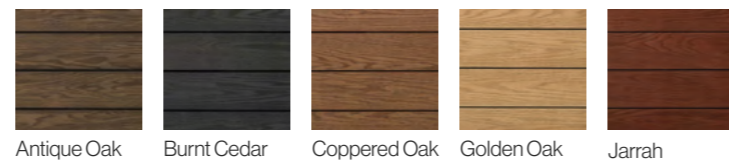

— Weathered Oak

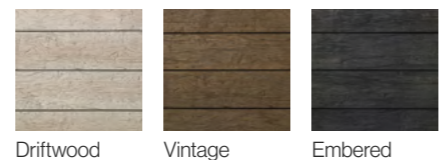

Tractio Decking

Effortless living

Profiles

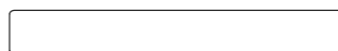

Solid 140mm wide
22mm thickness available



Solid 184mm wide
22mm thickness available

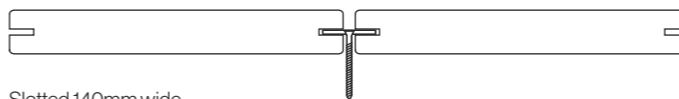

Slotted 140mm wide
22mm thickness available

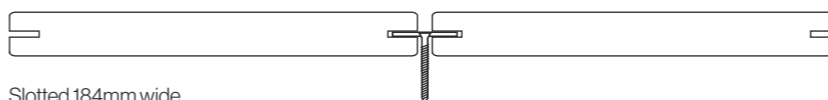

Slotted 184mm wide
22mm thickness available

Colours

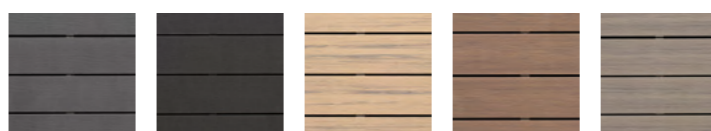

Alpine Grey Charred Desert Sand Forest Brown Weathered



Features and Benefits

Performance — Stain and fade-resistant

Compliance — P4 slip rating

Longevity — 25-year structural and fading warranty

Durability — The industry's best strength-to-weight ratio



Instyle Decking

Outdoor opulence

Profiles



88mm wide
20mm thickness available



135mm wide
20mm thickness available



Features and Benefits

Sustainable timber — Available in a range of sustainably certified hardwood timber species

Design — Concealing fixings

Durability — Designed to ensure maximum protection against rot

Quality — Manufactured using premium timber species that are seasoned in accordance with MXD1034.1 standards

Timber Species and Colours

- Timber species listed on page 50
- Timber coatings listed on page 51



Pencil Round Decking

Timeless outdoor sophistication

Profiles



86mm wide
19mm thickness available



136mm wide
19mm thickness available



145mm wide
21mm thickness available

Timber Species and Colours

- Timber species listed on page 50
- Timber coatings listed on page 51



Features and Benefits

Sustainable timber — Available in a range of sustainably certified hardwood timber species

Quality — Manufactured using premium timber species that are seasoned in accordance with MXD1034.1 standards



Timber Species

All our ranges of timber species are available in set length and random length. Please contact our projects team for more information.

— SOFTWOOD

Western Red Cedar, Alaskan Cedar & Hemlock are the only suitable species for 9mm thick profiles. All Softwood species can be used for 12mm thickness or greater. For external applications, please use 18mm thick profiles or greater.



Western Red Cedar

Plantation
100% PEFC Certified
Greentag Certified

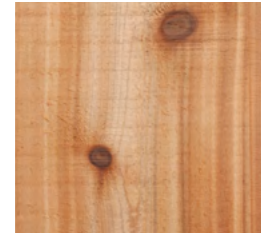

Western Red Cedar - Tight Knot

Plantation
100% PEFC Certified



Hemlock

Plantation
100% PEFC Certified
Suitable for indoor and
out-of weather use only



Hemlock - Thermally Modified

Plantation
100% PEFC Certified



Alaskan Cedar

Plantation
100% PEFC Certified



Accoya

Plantation
100% PEFC Certified

— HARDWOOD

Hardwood species can be used for 15mm thickness or greater for out of weather applications and 18mm thickness or greater for external use.



American Oak

PEFC Certification is available

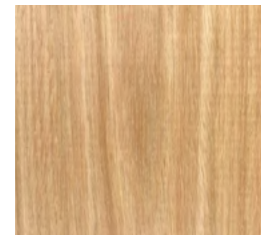

Blackbutt

FSC Certification is available

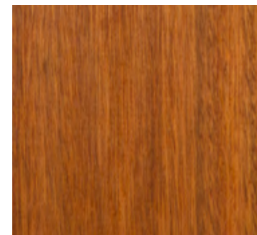

Spotted Gum

FSC Certification is available

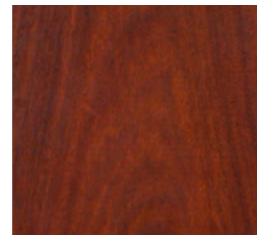

Ironbark

FSC Certification is available

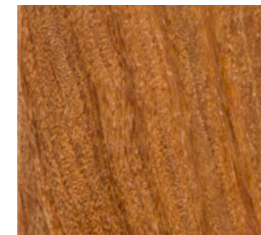

Southern Spotted

PEFC Certification is available



French Oak

PEFC Certification is available

Timber Finishes

Through our bespoke in-house manufacturing capabilities, our collection of standard finishes can be customised to meet your design intent. Below is an example of our range of timber finishes available.



Circular Sawn



Band Sawn



Shot Blasted



Wire Brushed



Two Tone

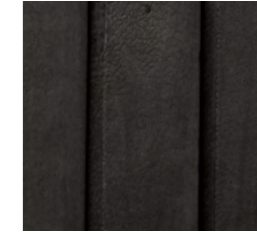

Charred - Shou Sugi Ban



Dressed

Timber Coatings

Modinex offers a range of standard and custom coating to meet our client's design requirements, whilst offering the best protection to our beautiful timber collections. All our coatings at Modinex are ultra-low VOC or VOC-free coatings. Please note some profiles are not available in all timber species.

Penetrating Oil Coatings

Penetrating oils can be used for both internal and external conditions. These oils penetrate the cellular structure of the timber giving it greater protection against UV and weathering. If you are looking for a natural patina finish, we can apply our mist or patina coatings to achieve a natural patina from installation. Penetrating oil achieve a natural matt finish.



Suitable for external conditions

Acid Catalysed Coatings

Acid catalysed coatings are commonly used for clear finishes in a matt or satin finish. These coatings are extremely hard-wearing.



Suitable for out-of-weather use only

UV Catalysed Coatings

UV catalysed coatings offer excellent surface projection to timber whilst being free of solvents and VOC free. UV coatings are available in matt or satin finish in a range of stain colours. UV coatings are one of the most sustainable and environmentally friendly coatings.



Suitable for out-of-weather use only

Custom Coatings

If one of our standard stain colours does not meet your design requirements, we can apply a custom coating in which we can colour match any colour.



Suitable for out-of-weather use only

For further information on our range of coatings and colour please contact our projects team hello@modinex.com.au. A range of our finishes are a combination of both Acid Catalysed and UV Catalysed coating technology.

Aluminium Timber Grain Finishes

— MXDURA

The MX Dura timber look finish is a next-generation signature double baked powder coat timber grain finish with a 3D grain, 25-year structural warranty and 15-year fading warranty for internal and external use.



Light Oak Tasmanian Oak Blackbutt Cedar White Oak Spotted Gum Dark Cedar

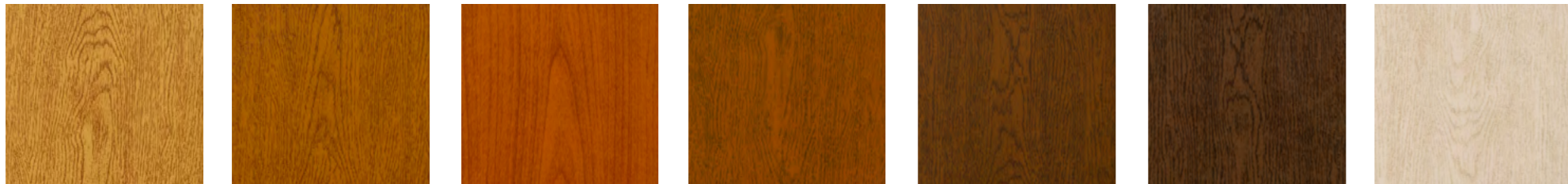

American Oak Brushbox Meranti English Oak Brown Oak Dark Smoked Oak Silvertop Ash



White Birch Silver Oak African Ebony Midnight Carbon



Solid Powder Coat Colours

*All Interpon or Dulux standard colours are available.

— ALPHA

The Alpha solid colour range is a collection of on trend solid colours, delivered with warranty grade advanced super durable polyester thermosetting powder.



Basalt Dune Natural White Shale Grey Surfmist Territory White
 Matt / Satin Matt / Satin Matt Matt / Satin Matt / Satin Matt Matt / Gloss



Talc Lunar Grey Silver Grey Timberland Charcoal Monument Black
 Satin Matt Matt Satin Satin Matt / Satin Matt



*All Interpon or Dulux standard colours are available.

— CHARISMA

The Charisma™ flat matt range features contemporary, solid colours in a flat matt finish for a subtle and sophisticated look, delivered with warranty grade advanced super durable polyester thermosetting powder.



Surfmist Flat Dune Flat Shale Grey Flat Bluegum Flat Basalt Flat Monument Flat Black Ace Flat

— STRUTTURA

The Struttura Range is a collection of popular, highly mark and scuff resistant textured finishes built to protect. Delivered with warranty grade advanced highly durable polyester thermosetting powder.



Natural White Flat Sufrmist Flat Shale Grey Flat Basalt Flat Monument Flat Black Flat CorTen Flat Textured



Suitable for external conditions

*All Interpon or Dulux standard colours are available.

— METTALICO

The Metallico anodised look range is a collection of unique anodised look finishes, designed to subtly change in appearance as light conditions after in the day, delivered with warranty grade advanced super durable polyester thermosetting powder.



Aged Brass Flat New Copper Flat Pale Bronze Flat Gold Pearl Flat Fresh Gold Flat Sensational Champagne Flat Brilliance Flat

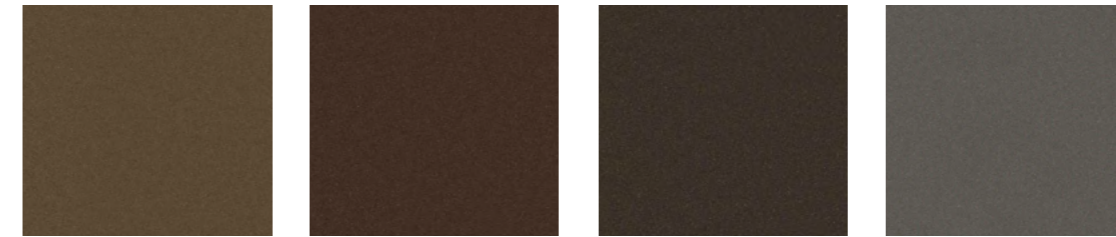

Medium Bronze Flat Burnished Copper Flat Dark Bronze Flat Venerable Silver Flat



Suitable for external conditions

Anodised Colours

— MATT

The traditional sophisticated matt lustre (10% Gloss).



Portland Stone — E60TM Amber Gold — E42TM Jamaican Chocolate — E42TM Summer Maize — E82GM Sovereign Gold — E78GM Maroochy Sand — E74GM Prosecco — E70RM

— ILLUSTR

Best of both, this hybrid provides an elegant look and feel (30% Gloss).

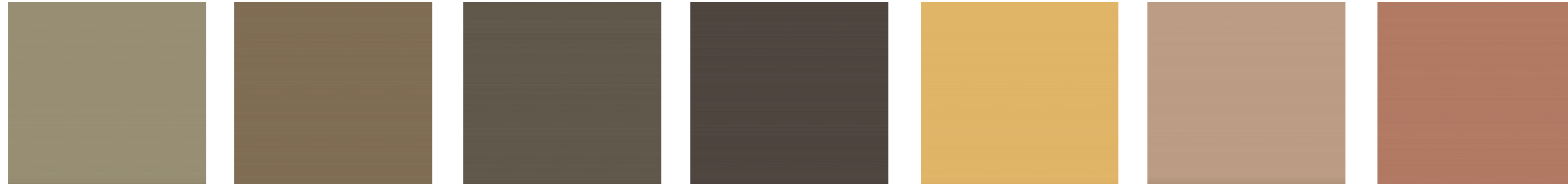

Bold as Brass — E58TL Medallion Bronze — E44TL Macchiato — E36TL Bronze Monument — E30TL Gold Odyssey — E78GL Blush — E64RL Copper Coin — E56RL

— BRIGHT

A brilliant finish that makes your product stand proud (80% Gloss).



Diamond Light — E87CB Moonbeam — E74NB Smokey Quartz — E60TB Smooth Onyx — E25TB Burnished Gold — E80GB



Suitable for external conditions





Let us help you specify your next project

Contact P—1800 156 455 E—hello@modinex.com.au

Inspiration and product downloads available at [modinex.com.au](https://www.modinex.com.au)